

**Agilent
7200 Accurate-Mass
Quadrupole
Time-of-Flight GC/MS
System**

Operation Manual



Agilent Technologies

Notices

© Agilent Technologies, Inc. 2012, 2014

No part of this manual may be reproduced in any form or by any means (including electronic storage and retrieval or translation into a foreign language) without prior agreement and written consent from Agilent Technologies, Inc. as governed by United States and international copyright laws.

Manual Part Number

G3850-90008

Edition

First Edition, August 2014

Printed in USA

Agilent Technologies, Inc.
5301 Stevens Creek Blvd.
Santa Clara, CA 95051

Warranty

The material contained in this document is provided “as is,” and is subject to being changed, without notice, in future editions. Further, to the maximum extent permitted by applicable law, Agilent disclaims all warranties, either express or implied, with regard to this manual and any information contained herein, including but not limited to the implied warranties of merchantability and fitness for a particular purpose. Agilent shall not be liable for errors or for incidental or consequential damages in connection with the furnishing, use, or performance of this document or of any information contained herein. Should Agilent and the user have a separate written agreement with warranty terms covering the material in this document that conflict with these terms, the warranty terms in the separate agreement shall control.

Technology Licenses

The hardware and/or software described in this document are furnished under a license and may be used or copied only in accordance with the terms of such license.

Restricted Rights Legend

U.S. Government Restricted Rights. Software and technical data rights granted to the federal government include only those rights customarily provided to end user customers. Agilent provides this customary commercial license in Software and technical data pursuant to FAR 12.211 (Technical Data) and 12.212 (Computer Software) and, for the Department of Defense, DFARS 252.227-7015 (Technical Data -Commercial Items) and DFARS 227.7202-3 (Rights in Commercial Computer Software or Computer Software Documentation).

Safety Notices

CAUTION

A **CAUTION** notice denotes a hazard. It calls attention to an operating procedure, practice, or the like that, if not correctly performed or adhered to, could result in damage to the product or loss of important data. Do not proceed beyond a **CAUTION** notice until the indicated conditions are fully understood and met.

WARNING

A **WARNING** notice denotes a hazard. It calls attention to an operating procedure, practice, or the like that, if not correctly performed or adhered to, could result in personal injury or death. Do not proceed beyond a **WARNING** notice until the indicated conditions are fully understood and met.

About This Manual

This manual contains information for operating and maintaining the Agilent 7200 Accurate-Mass Quadrupole Time-of-Flight GC/MS system.

1 “Introduction”

Chapter 1 describes general information about the 7200 Q-TOF GC/MS, including a hardware description, and general safety warnings.

2 “Installing GC Columns”

Chapter 2 shows you how to prepare a capillary column for use with the MS, install it in the GC oven, and connect it to the MS using the GC/MS interface.

3 “Operating in Electron Impact (EI) Mode”

Chapter 3 describes routine operations in EI mode such as setting temperatures, monitoring pressures, tuning, venting, and pumpdown.

4 “Operating in Chemical Ionization (CI) Mode”

Chapter 4 describes additional tasks necessary to operate in CI mode.

5 “Using the Removable Ion Source”

Chapter 5 shows you how to change the removable ion source.

6 “General Maintenance”

Chapter 6 describes general maintenance procedures for the 7200 Q-TOF GC/MS.

Hardware User Information

Accompanying your hardware and software is a comprehensive collection of manuals, videos, user applications, and method development tools. These are located on the:

- Agilent GC and GC/MS User Manuals and Tools DVD set
- Agilent GC/MS Software Information and Manuals memory stick



To Install Your Hardware Library

Insert Disk 1 into your DVD drive and follow the prompts.

This can be installed by anyone who has authority to copy information onto the receiving computer.



To Install Your Software Library

Insert the memory stick into a USB port and follow the prompts.

This can be installed by anyone who has authority to copy information onto the receiving computer.

See the Agilent 7200 Accurate Mass Q-TOF GC/MS System Quick Start document (G6845-90014) for more details on how to install this information on your computer.

Contents

1 Introduction

Abbreviations Used	10
The 7200 Accurate-Mass Quadrupole Time-of-Flight GC/MS System	12
Hardware Description	14
Important Safety Warnings	15
Safety and Regulatory Certifications	18
Intended Use	21
Cleaning/Recycling the Product	21
Liquid Spills	21
Moving or Storing the MS	21

2 Installing GC Columns

Columns	24
To Install a Capillary Column in a Split/Splitless Inlet	26
To Condition a Capillary Column	29
To Install a Capillary Column in the GC/MS Interface	30

3 Operating in Electron Impact (EI) Mode

Operating the MS from the Data System	34
The GC/MS Interface	35
Before You Turn On the MS	37
Pumping Down	38

Controlling Temperatures	38
Controlling Column Flow	38
Controlling Collision Cell Flow	39
Venting the MS	39
Typical Vacuum Pressures in EI Mode	40
To Set Monitors for Temperature and Vacuum Status	41
To Set the MS Analyzer Temperature	43
To Set the GC/MS Interface Temperature from the MassHunter Workstation	45
To Calibrate the Column	46
To Configure the Collision Cell Gas	48
To Set the Collision Cell Gas Flow Rate	49
To Autotune the MS for EI Mode	50
To Remove the Upper RIS Cover	52
To Open the Analyzer Cover for Access to the Analyzer Sideplate	53
To Pump Down the MS	54
To Vent the MS	56

4 Operating in Chemical Ionization (CI) Mode

Setting Up Your MS to Operate in CI Mode	58
The GC/MS Interface	59
Operating the CI MS	61
High Vacuum Pressure in CI Mode	62
Other Reagent Gases	63
CI Autotune	65
The Flow Control Module	66
To Switch from the EI Mode to CI Mode	67

To Operate the Reagent Gas Flow Control Module 69

To Set a Reagent Gas Flow 71

To Perform a CI Autotune 72

5 Using the Removable Ion Source

The Removable Ion Source 76

To Change the Ion Source 78

To Install the RIS Probe Extraction Tool 80

To Remove the Source from the Analyzer Chamber 82

To Change the Ion Source on the RIS Probe Extraction Tool 84

To Install the Ion Source in the Analyzer Chamber 86

To Remove the RIS Probe Extraction Tool from the Instrument 87

6 General Maintenance

Before Starting 90

Maintaining the Vacuum System 94

Maintaining the Analyzer 95

To Disassemble the EI Ion Source 97

To Assemble the EI Ion Source 99

To Disassemble the CI Ion Source 101

To Assemble the CI Ion Source 103

To Clean the Ion Source 105

To Remove a Filament 109

To Install a Filament 111

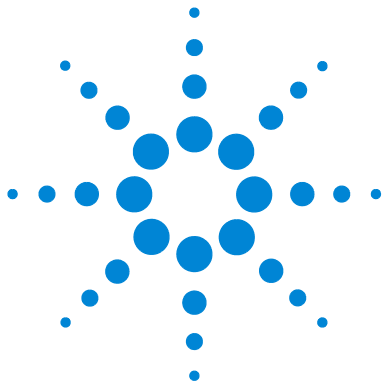

1 Introduction

Abbreviations Used	10
The 7200 Accurate-Mass Quadrupole Time-of-Flight GC/MS System	12
Hardware Description	14
Important Safety Warnings	15
Safety and Regulatory Certifications	18
Intended Use	21
Cleaning/Recycling the Product	21
Liquid Spills	21
Moving or Storing the MS	21

This section provides general information about the 7200 Accurate-Mass Quadrupole Time-of-Flight (Q-TOF) GC/MS System, including a hardware description, and general safety warnings.

Abbreviations Used

The abbreviations in [Table 1](#) are used in discussing this product. They are collected here for convenience.

Table 1 Abbreviations

Abbreviation	Definition
AC	Alternating current
ALS	Automatic liquid sampler
BFB	Bromofluorobenzene (calibrant)
CC	Collision cell
CI	Chemical ionization
DC	Direct current
DFTPP	Decafluorotriphenylphosphine (calibrant)
EI	Electron impact
EPC	Electronic pneumatic control
eV	Electron volt
GC	Gas chromatograph
id	Inside diameter
LAN	Local Area Network
m/z	Mass to charge ratio
MFC	Mass flow controller
MS	Mass spectrometer
NCI	Negative chemical ionization
OFN	Octafluoronaphthalene (sample)
PCI	Positive chemical ionization
PFDTD	Perfluoro-5,8-dimethyl-3,6,9-trioxododecane (calibrant)
PFET	2,4,6- <i>tris</i> (Pentafluoroethyl)-1,3,5-triazine

Table 1 Abbreviations (continued)

Abbreviation	Definition
PFTBA	Perfluorotributylamine (calibrant)
Q-TOF	Quadrupole time-of-flight
Quad	Quadrupole mass filter
RF	Radio frequency
RFPA	Radio frequency power amplifier
TOF	Time-of-flight
Torr	Unit of pressure, 1 mm Hg
Turbo	Turbomolecular vacuum pump

The 7200 Accurate-Mass Quadrupole Time-of-Flight GC/MS System

The 7200 Accurate-Mass Quadrupole Time-of-Flight (Q-TOF) GC/MS System is a standalone capillary GC detector for use with the Agilent 7890 Series gas chromatograph. The 7200 Q-TOF features:

- Three turbomolecular vacuum pumps
- Rotary vane foreline pump
- Independently MS-heated EI or CI ion source
- Removable ion source (RIS) probe with RIS bayonet and cooling chamber, which allows quick change from EI to CI ion source with minimal loss of vacuum in the instrument
- Independently MS-heated hyperbolic quadrupole mass filter, which can be heated to high temperatures, minimizing the contamination typical with low temperature analyses
- Single hexapole collision cell
- Ion-focusing slicer
- Vacuum-insulated flight tube with dual-stage ion mirror
- Fast electronics, allowing fast sampling rates
- Analog to digital detector
- Independently GC-heated GC/MS interface with automatic retraction during ion source removal

Physical description

The 7200 Q-TOF GC/MS is approximately 48 cm high, 71 cm wide, and 89 cm deep excluding the flight tube and RIS handle. The flight tube extends 84 cm over the top of the instrument. The RIS handle, when attached, extends 48 cm from the front of the instrument.

The weight of the instrument mainframe is 152 kg. The attached foreline (roughing) pump weighs an additional 21.5 kg.

The basic components of the instrument are: the frame/cover assemblies, the vacuum system, the GC/MS interface, the removable ion source, the flight tube electronics, the quadrupole mass filter, the collision cell, and the detector.

Vacuum gauge

The 7200 Q-TOF GC/MS is equipped with four ion vacuum gauges. The MassHunter Workstation can be used to read the pressure (high vacuum) in the vacuum manifold, the turbomolecular vacuum pump discharge, and the flight tube.

Ionization modes

The G3851BA 7200 Accurate-Mass Q-TOF GC/MS comes standard with both an EI source and a CI source.

For the CI system, a methane/isobutane gas purifier is provided and is required. It removes oxygen, water, hydrocarbons, and sulfur compounds.

The MS CI system has been optimized to achieve the relatively high ion source pressure required for CI while still maintaining high vacuum in the collision cell, quadrupole, and TOF tube. Special seals along the flow path of the reagent gas and very small openings in the ion source keep the ion source gases in the ionization volume long enough for the appropriate reactions to occur. The interface has special plumbing for reagent gas. A retractable insulating seal fits onto the tip of the interface and is used for both CI and EI.

Switching back and forth between CI and EI ion sources takes less than 30 minutes with the new removable ion source (RIS). The RIS allows the instrument to remain under vacuum, and provides a cooling chamber with N₂ purge for rapid ion source cooling without venting the machine. This saves hours in cycle time over the traditional unit.

Hardware Description

Figure 1 is an overview of a typical Agilent 7200 Accurate-Mass Q-TOF GC/MS system.

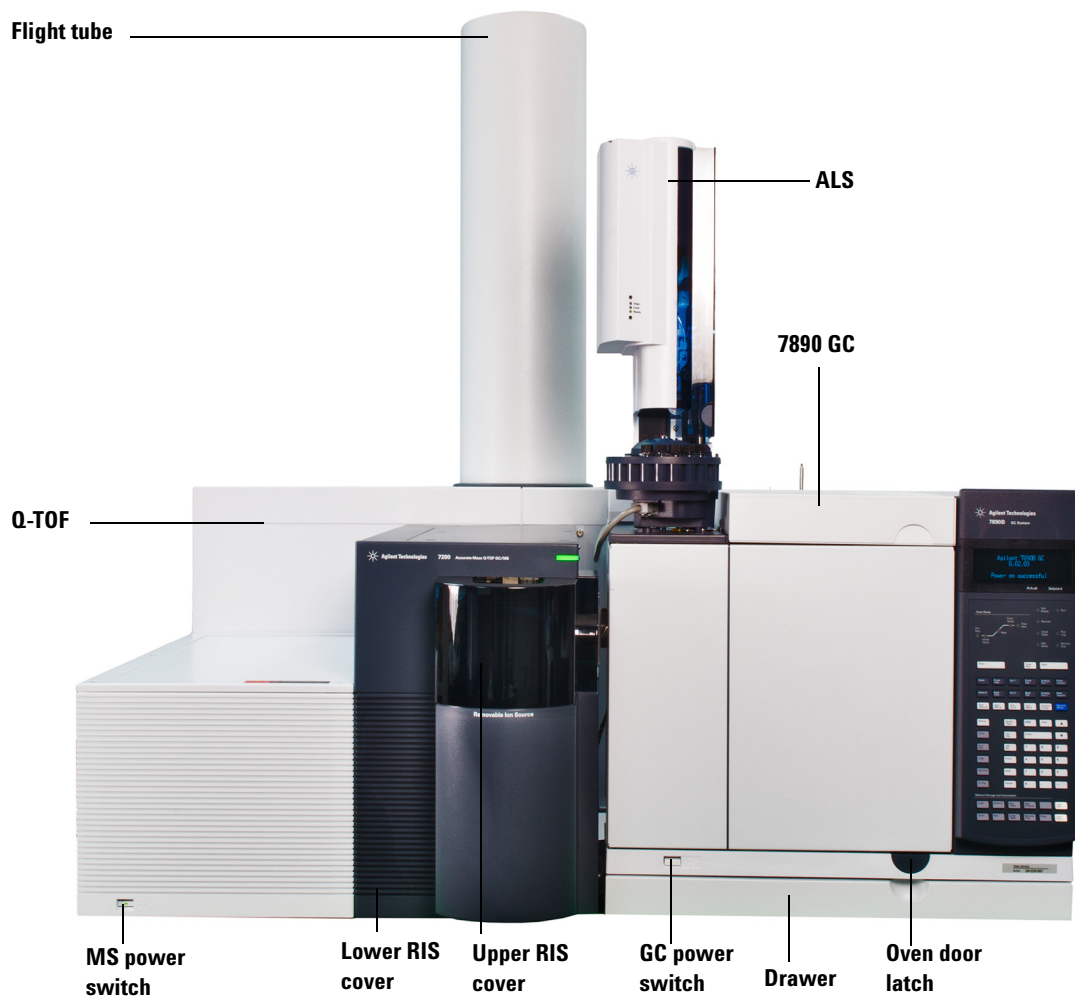

Figure 1 7200 Q-TOF GC/MS System

Important Safety Warnings

There are several important safety notices to always keep in mind when using the instrument.

Many internal parts of these instruments carry dangerous voltages

If the instrument is connected to a power source, even if the power switch is off, potentially dangerous voltages exist on:

- The wiring between the instrument power cord and the AC power supply
- The AC power supply itself
- The wiring from the AC power supply to the power switch

With the power switch on, potentially dangerous voltages also exist on:

- All electronics boards in the instrument
- The internal wires and cables connected to these boards
- The wires for any heater (oven, detector, inlet, or valve box)

WARNING

All these parts are shielded by covers. With the covers in place, it should be difficult to accidentally make contact with dangerous voltages. Unless specifically instructed to, never remove a cover unless the detector, inlet, and oven are turned off.

WARNING

If the power cord insulation is frayed or worn, the cord must be replaced. Contact your Agilent service representative.

Electrostatic discharge is a threat to instrument electronics

The printed circuit boards in these instruments can be damaged by electrostatic discharge. Do not touch any of the boards unless it is absolutely necessary. If you must handle them, wear a grounded wrist strap and take other antistatic precautions.

Precautions to take to prevent an explosion

WARNING

The use of hydrogen gas is specifically prohibited with this product.

WARNING

You **MUST** ensure the top thumbscrew on the front analyzer side plate and the top thumbscrew on the rear analyzer side plate are both fastened finger-tight. Do not over-tighten the thumbscrews; this can cause air leaks.

You **MUST** leave the collision cell chamber top plate shipping brackets fastened. Do not remove the shipping brackets from the top plate for normal operation; they secure the top plate in the event of an explosion.

WARNING

Failure to secure your MS as described above greatly increases the chance of personal injury in the event of an explosion.

Many parts are dangerously hot

Many parts of these instruments operate at temperatures high enough to cause serious burns. These parts include, but are not limited to the:

- Inlet
- Oven and its contents
- Valve box
- Column nuts attaching the column to an inlet, detector, or MS interface
- Foreline pump
- GC/MS transfer line

Always cool these areas of the system to room temperature before working on them. They will cool faster if you first set the temperature of the heated zone to room temperature. Turn the zone off after it has reached the setpoint. If you must perform maintenance on hot parts, use a wrench and wear gloves. Whenever possible, cool the part of the instrument that you will be maintaining before you begin working on it.

WARNING

Be careful when working behind the instrument. During cooldown cycles, the GC emits hot exhaust that can cause burns.

WARNING

The foreline pump can cause burns if touched when operating.

WARNING

The insulation around the inlets, detectors, valve box, and the insulation cups is made of refractory ceramic fibers. To avoid inhaling fiber particles, we recommend the following safety procedures: ventilate your work area; wear long sleeves, gloves, safety glasses, and a disposable dust/mist respirator; dispose of insulation in a sealed plastic bag in accordance with local regulations; wash your hands with mild soap and cold water after handling the insulation.

The oil pan under the standard foreline pump can be a fire hazard

Oily rags, paper towels, and similar absorbents in the oil pan could ignite and damage the pump and other parts of the MS.

WARNING

Combustible materials (or flammable/nonflammable wicking material) placed under, over, or around the foreline (roughing) pump constitutes a fire hazard. Keep the pan clean, and do not leave absorbent material such as paper towels in it.

Safety and Regulatory Certifications

The 7200 Q-TOF GC/MS conforms to the following safety standards:

- Canadian Standards Association (CSA): CAN/CSA-C22.2 No. 61010-1-04
- CSA/Nationally Recognized Test Laboratory (NRTL): UL 61010-1
- International Electrotechnical Commission (IEC): 61010-1
- EuroNorm (EN): 61010-1

The 7200 Q-TOF GC/MS conforms to the following regulations on Electromagnetic Compatibility (EMC) and Radio Frequency Interference (RFI):

- CISPR 11/EN 55011: Group 1, Class A
- IEC/EN 61326-1
- AUS/NZ 

This ISM device complies with Canadian ICES-001. Cet appareil ISM est conforme a la norme NMB-001 du Canada.



The 7200 Q-TOF GC/MS is designed and manufactured under a quality system registered to ISO 9001.

Information









The Agilent Technologies 7200 Accurate-Mass Q-TOF GC/MS meets the following IEC (International Electrotechnical Commission) classifications: Equipment Class I, Laboratory Equipment, Installation Category II, and Pollution Degree 2.

This unit has been designed and tested in accordance with recognized safety standards, and is designed for use indoors. If the instrument is used in a manner not specified by the manufacturer, the protection provided by the instrument may be impaired. Whenever the safety protection of the MS has been compromised, disconnect the unit from all power sources and secure the unit against unintended operation.

Refer servicing to qualified service personnel. Substituting parts or performing any unauthorized modification to the instrument may result in a safety hazard.

Symbols

Warnings in the manual or on the instrument must be observed during all phases of operation, service, and repair of this instrument. Failure to comply with these precautions violates safety standards of design and the intended use of the instrument. Agilent Technologies assumes no liability for the customer's failure to comply with these requirements.

See accompanying instructions for more information.	
Indicates a hot surface.	
Indicates hazardous voltages.	
Indicates earth (ground) terminal.	
Indicates potential explosion hazard.	 or 
Indicates radioactivity hazard.	
Indicates electrostatic discharge hazard.	
Indicates that you must not discard this electrical/electronic product in domestic household waste.	

Electromagnetic compatibility

This device complies with the requirements of CISPR 11. Operation is subject to the following two conditions:

- This device may not cause harmful interference.
- This device must accept any interference received, including interference that may cause undesired operation.

If this equipment does cause harmful interference to radio or television reception, which can be determined by turning the equipment off and on, the user is encouraged to try one or more of the following measures:

- Relocate the radio or antenna.
- Move the device away from the radio or television.
- Plug the device into a different electrical outlet, so that the device and the radio or television are on separate electrical circuits.
- Ensure that all peripheral devices are also certified.
- Ensure that appropriate cables are used to connect the device to peripheral equipment.
- Consult your equipment dealer, Agilent Technologies, or an experienced technician for assistance.

Changes or modifications not expressly approved by Agilent Technologies could void the user's authority to operate the equipment.

Sound emission declaration

Sound pressure

Sound pressure $L_p < 70$ dB according to EN 27779:1991 and EN ISO 3744:1995.

Schalldruckpegel

Schalldruckpegel $L_P < 70$ dB nach EN 27779:1991 und EN ISO 3744:1995.

Intended Use

Agilent products must only be used in the manner described in the Agilent product user guides. Any other use may result in damage to the product or personal injury. Agilent is not responsible for any damages caused, in whole or in part, by improper use of the products, unauthorized alterations, adjustments or modifications to the products, failure to comply with procedures in Agilent product user guides, or use of the products in violation of applicable laws, rules or regulations.

Cleaning/Recycling the Product

To clean the unit, disconnect the power and wipe down with a damp, lint-free cloth. For recycling, contact your local Agilent sales office.

Liquid Spills

Do not spill liquids on the MS.

Moving or Storing the MS

The best way to keep your MS functioning properly is to keep it pumped down and hot, with carrier gas flow. If you plan to move or store your MS, a few additional precautions are required. The MS must remain upright at all times; this requires special caution when moving. The MS should not be left vented to atmosphere for long periods. For more information, see “To Move or Store the MS” in the *Agilent 7200 Q-TOF GC/MS Troubleshooting and Maintenance Manual*.

1 Introduction

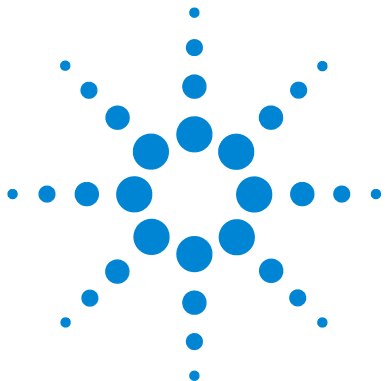

2 Installing GC Columns

Columns 24

To Install a Capillary Column in a Split/Splitless Inlet 26

To Condition a Capillary Column 29

To Install a Capillary Column in the GC/MS Interface 30

Before you can operate your GC/MS system, you must select, install, and condition a GC column. This chapter shows you how to install and condition a column.



Columns

Many types of GC columns can be used with the MS, but there are some restrictions.

During tuning or data acquisition the rate of column flow into the MS should not exceed the maximum recommended flow. Therefore, there are limits to column length and flow. Exceeding recommended flow will result in degradation of mass spectral and sensitivity performance.

Remember that column flows vary greatly with oven temperature. See [“To Calibrate the Column”](#) on page 46 for instructions on how to measure actual flow in your column. Use the flow calculator in the Agilent Instrument Utilities software, and [Table 2](#) to determine an acceptable column flow. For expected column outlet flow pressures, use the values shown in [Table 3](#) for EI mode and [Table 6](#) for CI mode.

Table 2 Gas flows

Feature	7200 Series
High-vacuum pump 1	Split flow turbo
High-vacuum pump 2	Split flow turbo
High-vacuum pump 3	Turbo
Optimal carrier gas flow, mL/min	1.0 to 1.5
Reagent gas flow, mL/min	1 to 2
Collision cell gas flow	1.5
Maximum recommended gas flow, mL/min*	2.0
Maximum gas flow, mL/min†	2.4
Maximum column id	0.32 mm (30 m length)

* Total gas flow into the MS = column flow + collision cell gas flow + reagent gas flow (if applicable) + Agilent Quick Swap flow (if applicable)

† Expect degradation of spectral performance and sensitivity.

Conditioning columns

Conditioning a column before it is connected to the GC/MS interface is essential.

A small portion of the capillary column stationary phase is often carried away by the carrier gas. This is called column bleed. Column bleed deposits traces of the stationary phase in the MS ion source. This decreases MS sensitivity and makes cleaning the ion source necessary.

Column bleed is most common in new or poorly cross-linked columns. It is much worse if there are traces of oxygen in the carrier gas when the column is heated. To minimize column bleed, all capillary columns should be conditioned *before* they are installed in the GC/MS interface.

Conditioning ferrules

Heating ferrules to their maximum expected operating temperature a few times before they are installed can reduce chemical bleed from the ferrules.

Tips and hints

- The column installation procedure for the 7200 Q-TOF GC/MS is different from that for other MSs. Using the procedure from another instrument may *not* work and may damage the column or the MS.
- You can remove old ferrules from column nuts with an ordinary pushpin.
- Always use carrier gas that is at least 99.9995% pure.
- Because of thermal expansion, new ferrules may loosen after heating and cooling a few times. Check for tightness after two or three heating cycles.
- Always wear clean gloves when handling columns, especially the end that will be inserted into the GC/MS interface.

WARNING

The use of hydrogen gas is specifically prohibited with this product.

WARNING

Always wear safety glasses when handling capillary columns. Use care to avoid puncturing your skin with the end of the column.

To Install a Capillary Column in a Split/Splitless Inlet



General Materials

- Gloves, clean
 - Large (8650-0030)
 - Small (8650-0029)
- Metric ruler
- Septum (may be old, used inlet septum)
- Wrench, open-end, 1/4-inch and 5/16-inch (8710-0510)

Self Tightening column nut materials (Recommended)

- Self Tightening column nut (5190-6194)
- Ferrules, Vespel for Self Tightening column nut
 - 5181-3323 Ferrule, 0.4mm VG 0.1-0.25 col 10 pk
 - 5062-3514 Ferrule, 0.5mm VG 0.32 col 10 pk

Traditional Universal column nut materials

- 5181-8830 Universal column nut, 2 pk
- Ferrules, Vespel for universal column nut
 - 5181-3323 Ferrule, 0.4mm VG 0.1-0.25 col 10 pk
 - 5062-3514 Ferrule, 0.5mm VG 0.32 col 10 pk

To install columns in other types of inlets, refer to your gas chromatograph user information.

Procedure

WARNING

The GC operates at high temperatures. In order to avoid burns, do not touch any parts of the GC until you are sure they are cool.

- 1 Cool the oven to room temperature.

CAUTION

Always wear clean gloves while handling any parts that go inside the GC or analyzer chambers.

- 2 Wearing clean gloves, slide a septum, column nut, and conditioned ferrule onto the free end of the column. **Figure 2** shows a traditional inlet column nut but the nut is similarly positioned for a self tightening column nut.

The tapered end of the ferrule should point away from the column nut for a column attachment to an inlet.

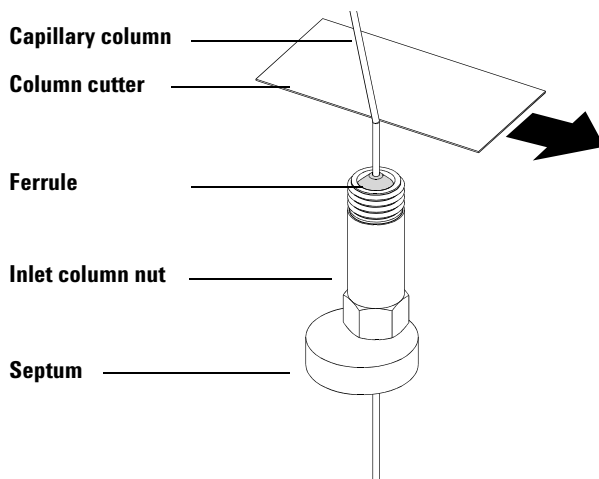

Figure 2 Preparing a capillary column for installation (standard inlet column nut shown)

- 3 Use the column cutter to score the column 2 cm from the end.
- 4 While holding the column against the column cutter with your thumb, break the column against the edge of the column cutter.
- 5 Inspect the end for jagged edges or burrs. If the break is not clean and even, repeat steps 3 and 4.
- 6 Wipe the outside of the free end of the column with a lint-free cloth moistened with methanol.
- 7 Position the septum under the column nut so that the column extends 4 to 6 mm past the end of the ferrule (**Figure 3**).

2 Installing GC Columns

- 8 Insert the column in the inlet.
- 9 Slide the nut up the column to the inlet base and finger-tighten the nut.
- 10 Adjust the column position so the septum is even with the bottom of the column nut.

CAUTION

Never use a wrench to tighten a self tightening nut. This may result in damage to the nut or instrument.

- 11 For the Self Tightening column nut, finger-tighten until it begins to grip the column then turn an additional 30 to 60 degrees until tight.

For the traditional column nut tighten the nut an additional 1/4 to 1/2 turn. The column should not slide with a gentle tug.

- 12 Start carrier gas flow.
- 13 Verify flow by submerging the free end of the column in isopropanol. Look for bubbles.

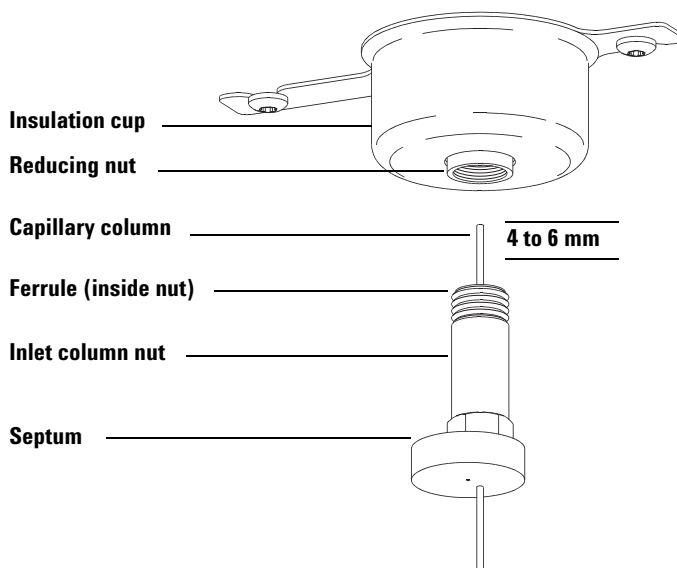

Figure 3 Installing a capillary column for a split/splitless inlet
The traditional inlet column nut is shown and the recommended self tightening inlet column nut is also provided but not shown.

To Condition a Capillary Column



Materials needed

- Carrier gas, (99.9995% pure or better)
- Wrench, open-end, 1/4-inch and 5/16-inch (8710-0510)

WARNING

The use of hydrogen gas is specifically prohibited with this product.

WARNING

The GC operates under high temperatures. To avoid burns, do not touch any GC parts unless you are certain they are cool.

Procedure

- 1 Install the column in the GC inlet. (See “[To Install a Capillary Column in a Split/Splitless Inlet](#)” on page 26.)
- 2 Set a minimum velocity of 30 cm/s, or as recommended by the column manufacturer. Allow gas to flow through the column at room temperature for 15 to 30 minutes to remove air.
- 3 Program the oven from room temperature to the maximum temperature limit for the column.
- 4 Increase the temperature at a rate of 10 to 15 °C/min.
- 5 Hold at the maximum temperature for 30 minutes.

CAUTION

Never exceed the maximum column temperature, either in the GC/MS interface, the GC oven, or the inlet.

- 6 Set the GC oven temperature to 30 °C and wait for the GC to become ready.
- 7 Attach the column to the GC interface. (See “[To Install a Capillary Column in the GC/MS Interface](#)” on page 30.)

For more information about installing a capillary column, refer to *Optimizing Splitless Injections on Your GC for High Performance MS Analysis*, Agilent Technologies publication number 5988-9944EN.

To Install a Capillary Column in the GC/MS Interface



This procedure is for the installation of a capillary column directly into the analyzer using the Agilent recommended self-tightening column nut.

Materials needed

- Column cutter, ceramic (5181-8836) or diamond (5183-4620)
- Flashlight
- Magnifying loupe
- Gloves, clean
 - Large (8650-0030)
 - Small (8650-0029)
- Septum (may be old, used inlet septum)
- Safety glasses
- Column install tool (G3850-60014)

Self Tightening column nut materials (Recommended)

- Self Tightening column nut (5190-5233)
- Ferrules, Vespel for Self Tightening column nut
 - 5181-3323 Ferrule, 0.4 mm VG 0.1-0.25 col 10 pk
 - 5062-3514 Ferrule, 0.5 mm VG 0.32 col 10 pk

Traditional MS interface nut materials

- MS Interface column nut (05988-20066)
- Ferrules, Vespel for universal column nut
 - 5181-3323 Ferrule, 0.4 mm VG 0.1-0.25 col 10 pk
 - 5062-3514 Ferrule, 0.5 mm VG 0.32 col 10 pk

Procedure

CAUTION

Always wear clean gloves while handling any parts that go inside the GC or the analyzer chambers.

- 1 Condition the column. (See [“To Condition a Capillary Column”](#) on page 29.)

WARNING

The analyzer, GC/MS interface, and other components in the analyzer chamber operate at very high temperatures. Do not touch any part until you are sure it is cool.

WARNING

Dangerous voltages exist inside the analyzer chamber, which can result in fatal injury. Do not open the analyzer chamber door for any reason. If access is ever required, trained service personnel must first disconnect the instrument from the building power source.

- 2 Vent the MS. To vent the MS, see [“To Vent the MS”](#) on page 56.

WARNING

The GC operates under high temperatures. To avoid burns, do not touch any GC parts unless you are certain they are cool.

- 3 Slide the Self Tightening or standard column interface nut and conditioned ferrule onto the free end of the GC column. The tapered end of the ferrule must point towards the nut.
- 4 Insert the column into the column install pre-swaging tool, and allow the end of the column to project past the end of the tool.
- 5 Use the column cutter to score the column 2 cm from its end.
- 6 While holding the column against the column cutter with your thumb, break the column against the edge of the column cutter.
- 7 Inspect the end for jagged edges or burrs. If the break is not clean and even, repeat steps 5 and 6.

2 Installing GC Columns

- 8 Wipe the outside of the free end of the column with a lint-free cloth moistened with methanol.
- 9 Slide the column so that the end projects 4–5 mm past the end of the column install pre-swaging tool.
- 10 For the Self Tightening column nut, finger-tighten until it begins to grip the column then turn an additional 30 to 60 degrees until tight.

For the traditional column nut, tighten the nut an additional 1/4 to 1/2 turn. The column should not slide with a gentle tug.

- 11 Loosen the column nut and remove the column from the tool.
- 12 Slide the column into the GC/MS interface.
- 13 Hand-tighten the nut. Ensure the position of the column does not change as you tighten the nut.
- 14 Check the GC oven to be sure that the column does not touch the oven walls.
- 15 Check the nut's tightness after one or two heat cycles; retighten as appropriate.

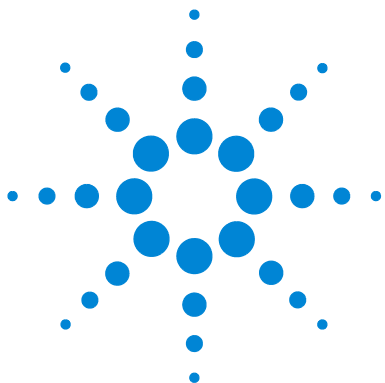

3 Operating in Electron Impact (EI) Mode

Operating the MS from the Data System	34
The GC/MS Interface	35
Before You Turn On the MS	37
Pumping Down	38
Controlling Temperatures	38
Controlling Column Flow	38
Controlling Collision Cell Flow	39
Venting the MS	39
Typical Vacuum Pressures in EI Mode	40
To Set Monitors for Temperature and Vacuum Status	41
To Set the MS Analyzer Temperature	43
To Set the GC/MS Interface Temperature from the MassHunter Workstation	45
To Calibrate the Column	46
To Configure the Collision Cell Gas	48
To Set the Collision Cell Gas Flow Rate	49
To Autotune the MS for EI Mode	50
To Remove the Upper RIS Cover	52
To Open the Analyzer Cover for Access to the Analyzer Sideplate	53
To Pump Down the MS	54
To Vent the MS	56

This chapter will explain how to perform some routine operating procedures for the 7200 Accurate-Mass Q-TOF GC/MS in EI mode.



Operating the MS from the Data System

The Agilent MassHunter Data Acquisition Workstation automates tasks such as pumping down, removing the ion source, monitoring settings, setting temperatures, tuning, and venting the MS. These tasks are described in this chapter. Additional information is described in the manuals and online help supplied with the MassHunter Workstation software.

CAUTION

The software and firmware are revised periodically. If the steps in these procedures do not match your MassHunter Workstation software, refer to the manuals and online help supplied with the software for more information.

Your G3851BA 7200 Q-TOF GC/MS provides the capability of operating in either EI or CI modes, using the new RIS technology. You must specify the type of ionization you are using in the Acquisition software tune file used by your method.

The GC/MS Interface

The GC/MS interface ([Figure 4](#)) is a heated conduit into the MS for the capillary column. The interface is bolted onto the right side of the front analyzer chamber and has an O-ring seal. It has a protective insulated cover that should be left in place.

One end of the GC/MS interface passes through the side of the gas chromatograph and extends into the GC oven. This end is threaded to allow connection of the column with a nut and ferrule. The other end of the interface fits into the ion source. The last 4 to 5 mm of the capillary column extends past the end of the guide tube and into the ionization chamber. When changing the removable ion source, the interface is automatically retracted from the ion source by the MassHunter software. This allows the ion source to slide freely in and out of the analyzer chamber.

The GC/MS interface is heated by an electric cartridge heater. Normally, the heater is powered and controlled by the Thermal Aux #2 heated zone of the GC. The interface temperature can be set from the MassHunter Workstation or from the gas chromatograph keypad. A sensor (thermocouple) in the interface monitors the temperature.

The GC/MS interface generally operates in the 250 to 350 °C range. Subject to that restriction, the interface temperature should be slightly higher than the maximum GC oven temperature, but *never* higher than the maximum column temperature.

See also

[“To Install a Capillary Column in the GC/MS Interface”](#) on page 30.

WARNING

The GC/MS interface operates at high temperatures. If you touch it when it is hot, it will burn you.

3 Operating in Electron Impact (EI) Mode

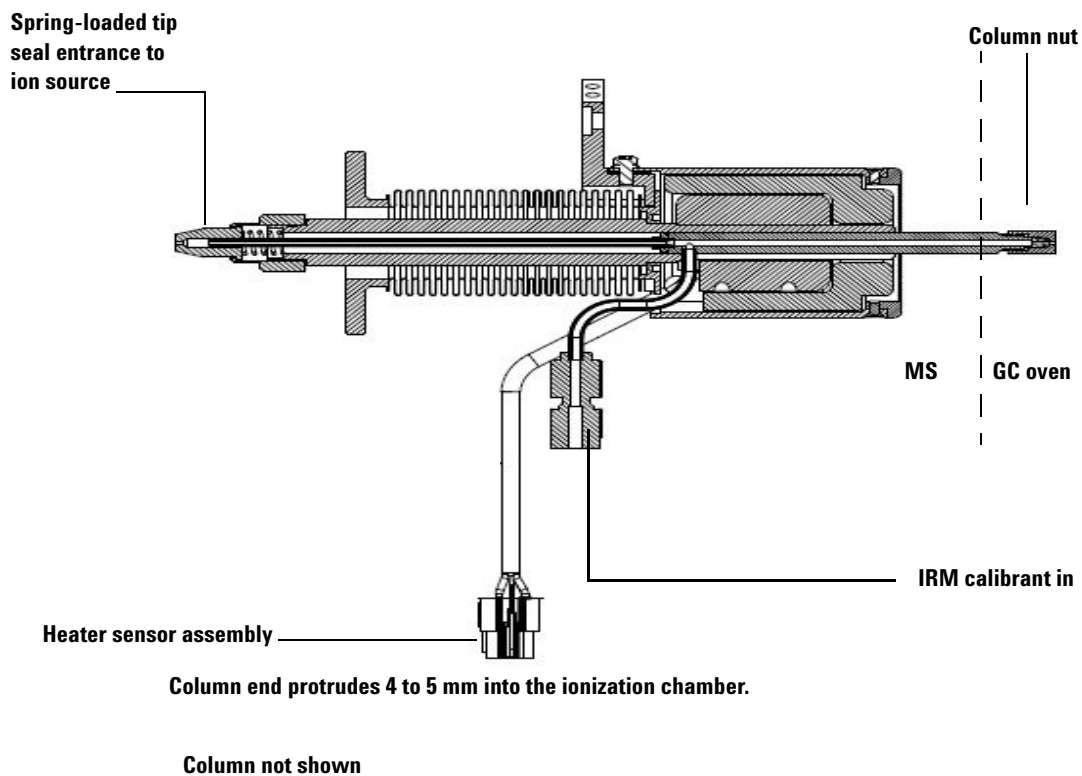

Figure 4 The GC/MS interface

Before You Turn On the MS

Verify the following *before* you turn on or attempt to operate the MS.

- All vacuum seals and fittings must be in place and fastened correctly. The analyzer plate thumbscrew should be unfastened, unless hazardous carrier or reagent gases are being used.
- The MS is connected to a grounded power source.
- The GC/MS interface extends into the GC oven.
- A conditioned capillary column is installed in the GC inlet and in the GC/MS interface.
- The GC is on, but the heated zones for the GC/MS interface, the GC inlet, and the oven are off.
- Carrier gas of at least 99.9995% purity is plumbed to the GC with the recommended traps.
- The use of hydrogen gas is specifically prohibited with this product.
- The foreline pump exhaust is properly vented.

WARNING

The exhaust from the foreline pump contains solvents and the chemicals you are analyzing. The standard foreline pump, also exhausts traces of pump oil. If you are using toxic solvents or analyzing toxic chemicals, attach a hose (11-mm id) to the oil mist filter to take the foreline pump exhaust outside or to a fume (exhaust) hood. Be sure to comply with local regulations. The oil mist filter supplied with the standard pump stops only pump oil. It does not trap or filter out toxic chemicals.

WARNING

The use of hydrogen gas is specifically prohibited with this product.

Pumping Down

Pumping down is only required if the analyzer was vented. It is not required for changing the ion source.

The data system helps you pump down the MS. The process is mostly automated. When you turn on the main power switch (while pressing on the analyzer sideplate), the MS pumps down by itself. The data system software monitors and displays system status during pumpdown. When the pressure is low enough, the program turns on the ion source and mass filter heaters and prompts you to turn on the GC/MS interface heater. The MS will shut down if it cannot pump down correctly.

Using the MS monitors, the data system can display:

- Motor speed for each MS turbo pump
- Analyzer chamber pressure (vacuum)
- Quadrupole and ion source temperatures

Controlling Temperatures

MS temperatures are controlled through the data system. The MS has independent heaters and temperature sensors for the ion source and the quadrupole mass filter. You can adjust the setpoints and view these temperatures from the data system

The GC/MS interface heater is powered and controlled by the Thermal Aux #2 heated zone of the GC. The GC/MS interface temperature can be set and monitored from the data system or from the GC keypad.

Controlling Column Flow

Carrier gas flow is controlled by column inlet pressure in the GC. For a given inlet pressure, column flow will decrease as the GC oven temperature increases. With electronic pneumatic control (EPC) and the column mode set to **Constant Flow**, the same column flow is maintained regardless of temperature.

The MS can be used to measure actual column flow. You inject a *small* amount of air or other unretained chemical and time how long it takes to reach the MS. With this time measurement, you can calculate the column flow. See “[To Calibrate the Column](#)” on page 46.

Controlling Collision Cell Flow

The collision cell gas flow rate is controlled by an EPC module located in the GC. The collision cell gas flow consists of nitrogen. The gas pressure at the EPC outlet controls the flow of the gas. This pressure is controlled by the MassHunter Data Acquisition Workstation or directly at the GC keypad. See “[To Set the Collision Cell Gas Flow Rate](#)” on page 49.

Venting the MS

A program in the data system automates the venting process. It turns off the GC and MS heaters and the turbo pump at the correct time.

The Fast Vent feature loads a user-defined GC method that sets an oven temperature, turns off the transfer line heater and sets the column flow to a user predefined level.

The MS *will* be damaged by incorrect venting. A turbo pump will be damaged if it is vented while spinning at more than 50% of its normal operating speed.

WARNING

The use of hydrogen gas is specifically prohibited with this product.

CAUTION

Never vent the MS by allowing air in through either end of the foreline hose. Use the vent valve or remove the column nut and column.

Do not exceed the maximum recommended total gas flow. See [Table 2](#).

Typical Vacuum Pressures in EI Mode

The largest influences on operating pressure in EI mode are the carrier gas (column) and collision cell gas flows. Table 3 lists typical pressures for various helium and nitrogen collision cell gas flows. These pressures are approximate and will vary from instrument to instrument by as much as 30%.

Table 3 Influence of carrier and collision cell gas flows on vacuum

Column Flow (mL/min)	CC Gas On N ₂ = 1.5 mL/min			CC Gas Off		
	Rough Vac	Quad Vac	TOF Vac	Rough Vac	Quad Vac	TOF Vac
0.5	1.16×10^{-1}	3.41×10^{-5}	4.20×10^{-7}	8.29×10^{-2}	3.17×10^{-7}	2.15×10^{-7}
0.7	1.18×10^{-1}	3.41×10^{-5}	4.20×10^{-7}	8.67×10^{-2}	3.45×10^{-7}	2.15×10^{-7}
1	1.22×10^{-1}	3.43×10^{-5}	4.22×10^{-7}	9.17×10^{-2}	3.79×10^{-7}	2.16×10^{-7}
1.2	1.24×10^{-1}	3.43×10^{-5}	4.22×10^{-7}	9.49×10^{-2}	4.06×10^{-7}	2.16×10^{-7}
2	1.32×10^{-1}	3.44×10^{-5}	4.22×10^{-7}	1.07×10^{-1}	5.17×10^{-7}	2.17×10^{-7}
3	1.42×10^{-1}	3.44×10^{-5}	4.25×10^{-7}	1.19×10^{-1}	6.51×10^{-7}	2.20×10^{-7}
4	1.50×10^{-1}	3.46×10^{-5}	4.27×10^{-7}	1.29×10^{-1}	7.84×10^{-7}	2.21×10^{-7}

If the pressure is consistently higher than those listed, refer to the online help in the MassHunter Workstation software for information on troubleshooting air leaks and other vacuum problems.

To Set Monitors for Temperature and Vacuum Status

A monitor displays the current value of a single instrument parameter. They can be added to the standard instrument control window. Monitors can be set to change color if the actual parameter varies beyond a user-determined limit from its setpoint.

Procedure

- 1 Select **Instrument > Edit Monitors** to display the **Select Monitors** dialog box. See [Figure 5](#).

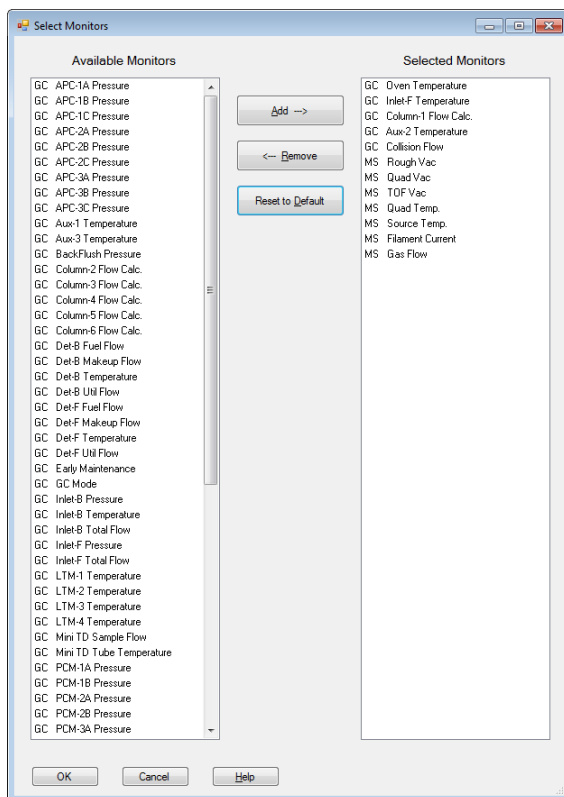

Figure 5 Select Monitors dialog box

3 Operating in Electron Impact (EI) Mode

- 2 In the **Available Monitors** column, select a monitor and click the **Add** button to move the selected monitor to the **Selected Monitors** column.
- 3 Select any other monitors you want and add them to the **Selected Monitors** column.
- 4 Click **OK**. The new monitors will be stacked on top of each other in the lower right corner of the **Instrument Control** window.
- 5 Select **Window > Arrange Monitors**, or click and drag each monitor to the desired position. See [Figure 6](#) for one way of arranging the monitors.

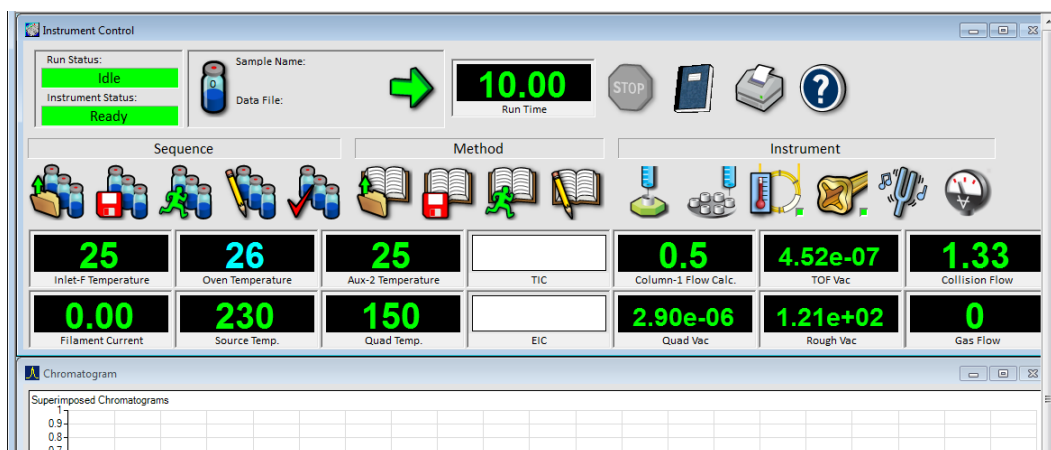

Figure 6 Arranging monitors

- 6 To make the new settings part of the method, select **Save** from the **Method** menu.

To Set the MS Analyzer Temperature

Setpoints for the MS ion source and quad temperatures are stored in the current tune file. When a method is loaded, the setpoints in the tune file associated with that method are downloaded automatically.

Procedure

- 1 In **Instrument Control** panel, select the **MS Tune** icon to display the **Tune** dialog box. Select the **Manual Tune** tab then select the **Ion Source** tab to display the ion source parameters.
- 2 Enter the temperature setpoint in the **Source Temp** field. See [Table 4](#) for recommended setpoints.
- 3 Select the **Quadrupole** tab to display the MS parameters.
- 4 Enter the temperature setpoint in the **Quad Temp** field. See [Table 4](#) for recommended setpoints.
- 5 Select the **Files and Reports** tab then click the **Save** button to save the tune file with these changes.

Table 4 Recommended temperature settings

Zone	EI operation
MS Source	230 °C
MS Quad	150 °C

3 Operating in Electron Impact (EI) Mode

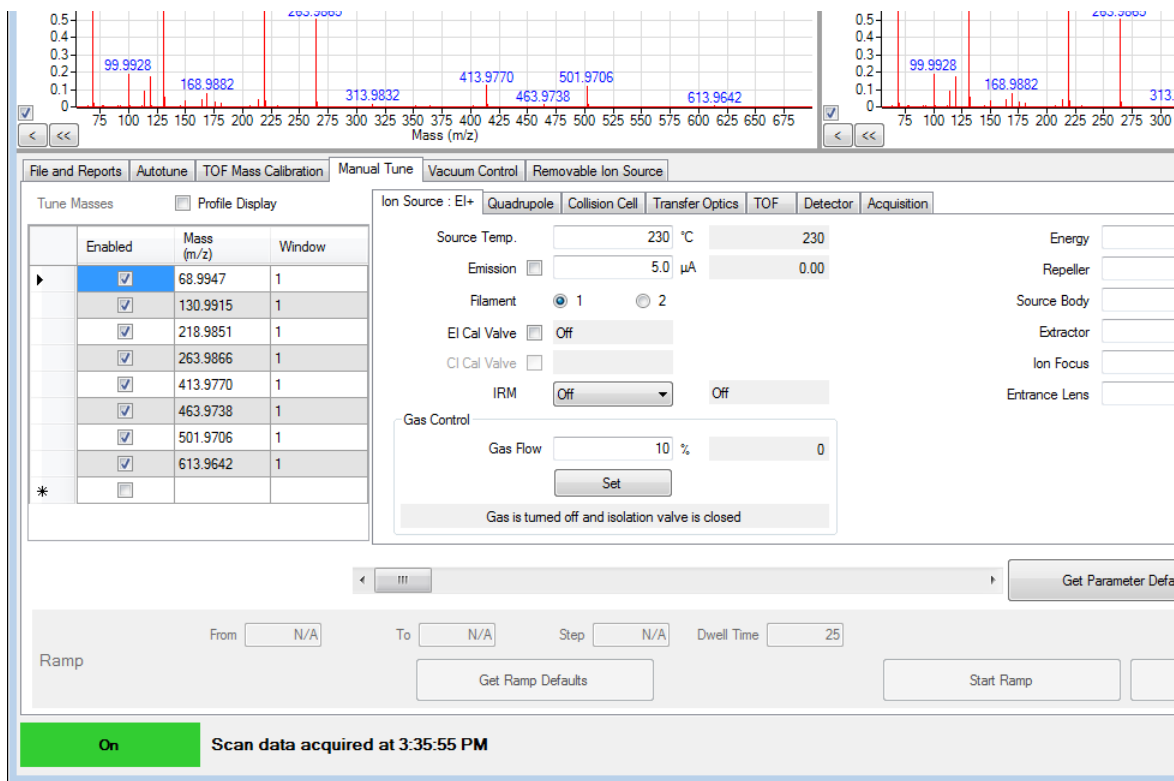

Figure 7 Setting temperatures

The GC/MS interface, ion source, and the MS quadrupole heated zones interact. The analyzer heater may not be able to accurately control temperature if the setpoint for one zone is much different from that of an adjacent zone.

WARNING

The software will not allow you to exceed 200 °C for the quadrupole, or 350 °C for the ion source.

To Set the GC/MS Interface Temperature from the MassHunter Workstation

You can also use the **GC Control** panel to perform this task.

Procedure

- 1 Select **Instrument > GC Parameters** from the **Instrument Control** panel.
- 2 Click the **Aux Heaters** icon to edit the interface temperature (Figure 8). This example has the GC/MS interface temperature configured as **Thermal Aux 2**.

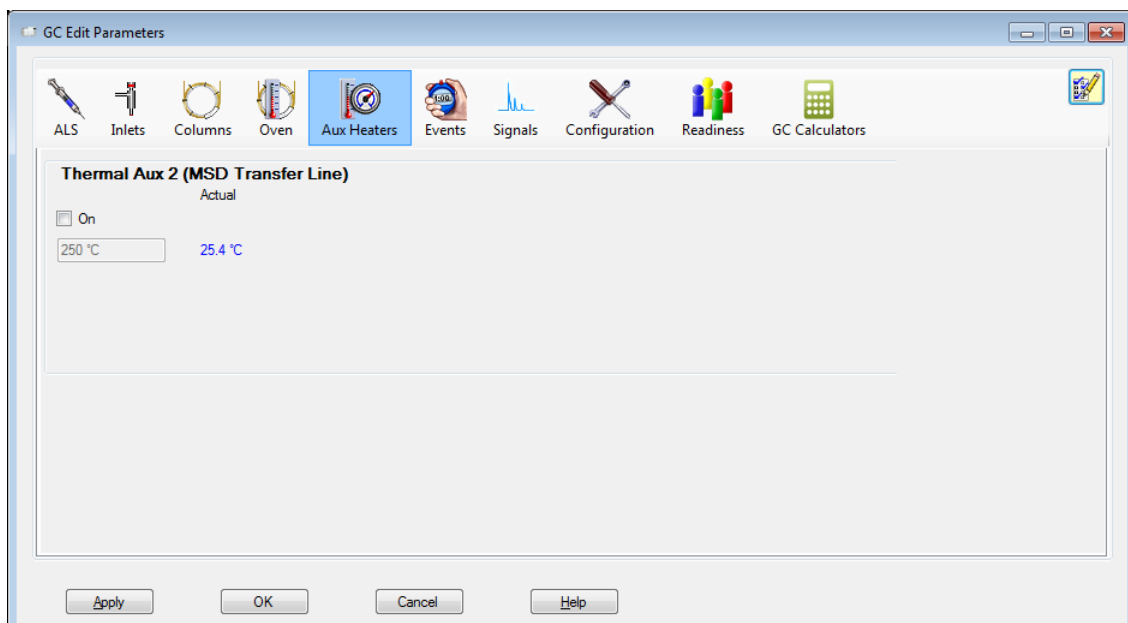

Figure 8 Setting the interface temperature

CAUTION

Ensure that the carrier gas is turned on and the column has been purged of air before heating the GC/MS interface or the GC oven.

CAUTION

When setting the GC/MS interface temperature, never exceed the maximum for your column.

- 3 Click the heater **On** check box and enter the setpoint in the **Value °C** column. The typical setpoint is 280 °C. The limits are 0 °C to 400 °C. A setpoint below ambient temperature turns off the interface heater.
- 4 Click **Apply** to download setpoints or click **OK** to download setpoints and close the window.
- 5 To make the new settings part of the method, select **Save** from the **Method** menu.

To Calibrate the Column

Capillary columns must be calibrated prior to use with the MS.

Procedure

- 1 Set Data Acquisition for splitless manual injection and set up a real time plot to monitor m/z 28.
- 2 Press [**Prep Run**] on the GC keypad.
- 3 Inject 1 μ L of air into the GC inlet and press [**Start Run**]
- 4 Wait until a peak elutes at m/z 28. Note the retention time.
- 5 In the **Instrument Control** panel, select .
- 6 Select the **Configuration** tab.
- 7 Select the **Column** tab and from the table, then select the column to be calibrated and click **Calibrate**.
- 8 Select the **Calc Length** button.
- 9 In the **Calculate Column Length** dialog box, enter the recorded retention time in the **Holdup Time of an Unretained Peak** field.
- 10 Verify that the other parameters listed (temperature, inlet and outlet pressures, and gas type) are those used in the method to determine the holdup time. Change any parameters that are different than those used in your method.

Calculate Column Length

GC Conditions

If measurement was made under conditions different from loaded method, please enter them below.

Temperature: 45 °C

Pressure into column: 9.4667 psi

Pressure out of column: 0 psi

Vacuum

Gas type: He

Holdup Time of an Unretained Peak: 1.2555 min

	Current	Calculated
▶ Length	30 m	30 m
Diameter	250 µm	250 µm
Holdup	1.2555 min	1.2555 min

OK Cancel

Figure 9 Calculate Column Length dialog box

- 11** When the new column length appears, click **OK** to save the changes.
- 12** Click **OK** on the **Calibrate Columns** screen to save the calibration.

To Configure the Collision Cell Gas

- 1 From the **MassHunter Data Acquisition Workstation Instrument Control** panel, select .
- 2 Click the **Configuration** icon and select the **Modules** tab to display the screen. See [Figure 10](#).

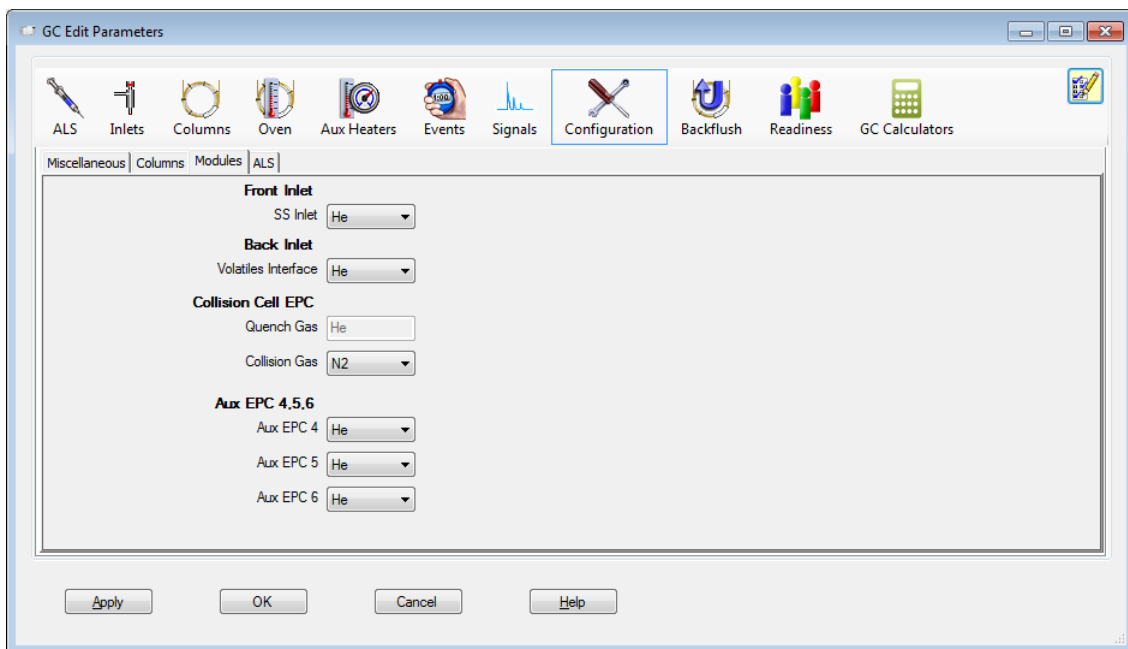

Figure 10 Configure the collision cell gas

- 3 From the **Collision Cell EPC** drop-down menu, select **N2** as the collision cell gas.
- 4 Click **OK** to save the configuration.

To Set the Collision Cell Gas Flow Rate

- 1 From the MassHunter Data Acquisition Workstation **Instrument Control** panel, select **Instrument > GC Parameters**.
- 2 Click the **Columns** icon to display control parameter entry screen for column and Aux flow modules. See [Figure 11](#).
- 3 Select **Collision Cell EPC** in the **Selection** list.
- 4 Enter the required gas flow rates in the appropriate fields.
- 5 Click the **N2 Collision Gas** check box to allow the N2 collision gas flow.
- 6 Click **Apply** to download the setpoints or **OK** to download the setpoints and close the window.
- 7 To make the new settings part of the method, select **Save** from the **Method** menu.

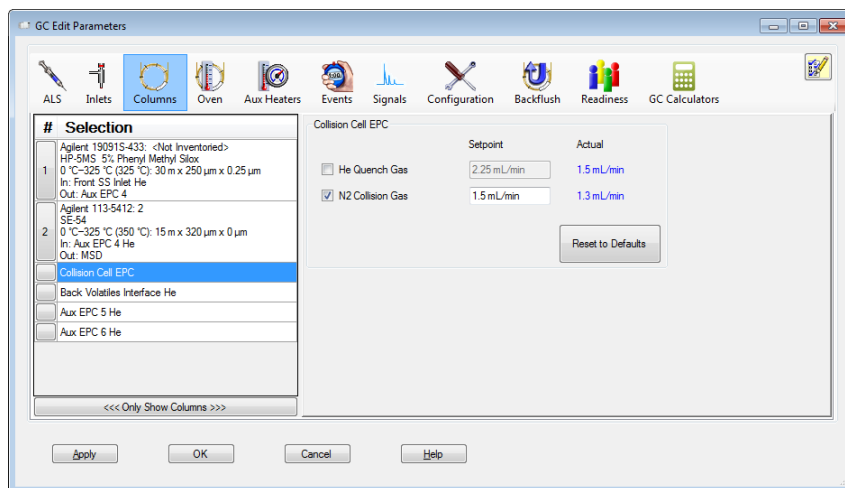

Figure 11 Setting the collision cell gas flow rate

To Autotune the MS for EI Mode

The MS can be tuned using the MassHunter Workstation software.

Procedure

- 1 Set the system to the same conditions (GC oven temperature and column flow, and MS analyzer temperature) that will be used for data acquisition.
- 2 In the **Instrument Control** panel, click the **MS Tune** icon to display the **GC/Q-TOF Tune** dialog box.
- 3 The current tune file is displayed in the upper left corner of the **GC/Q-TOF Tune** dialog box. Verify that the correct tune file is loaded.
- 4 If necessary, load a new tune file by clicking on the **Files and Report** tab then click on the **Load** button in the **Tune File** area. Select a tune file and click the **OK** button.

The tune file must match the type of ion source in the analyzer. If you are using an EI ion source, select a tune file created for an EI ion source.

- 5 Click the **Autotune** tab and select the **Tune from default settings** check box if you are restarting the system after a system vent, major servicing, or a power outage. If you clear the **Tune from default settings** box, the autotune process starts using the previous tune values.
- 6 Select **Save tune file when done** check box to save the new tune parameters generated by the autotune. Do not select this item if you want to review the autotune report before saving the newly generated tune parameters.
- 7 Select the **Print autotune report** check box to automatically print a tune report.
- 8 Click the **Autotune** button to start the autotune. The **Status** line displays the current step in the autotune process and the plot of the tuned parameter for that step is shown in the top graph. If specified above, at the completion of the autotune, a Tune Report is printed.

To stop the autotune before it completes the automatic parameter selection, click the **Abort Tune** button. The parameters from the last successful autotune are used.

- 9 Review the Tune Report. If the results are acceptable and you did not select the **Save tune file when done** check box, save the autotune by clicking the **Files and Report** tab, then click the **Save** button.

See the manuals or online help provided with your MassHunter Data Acquisition Workstation software for additional information about tuning.

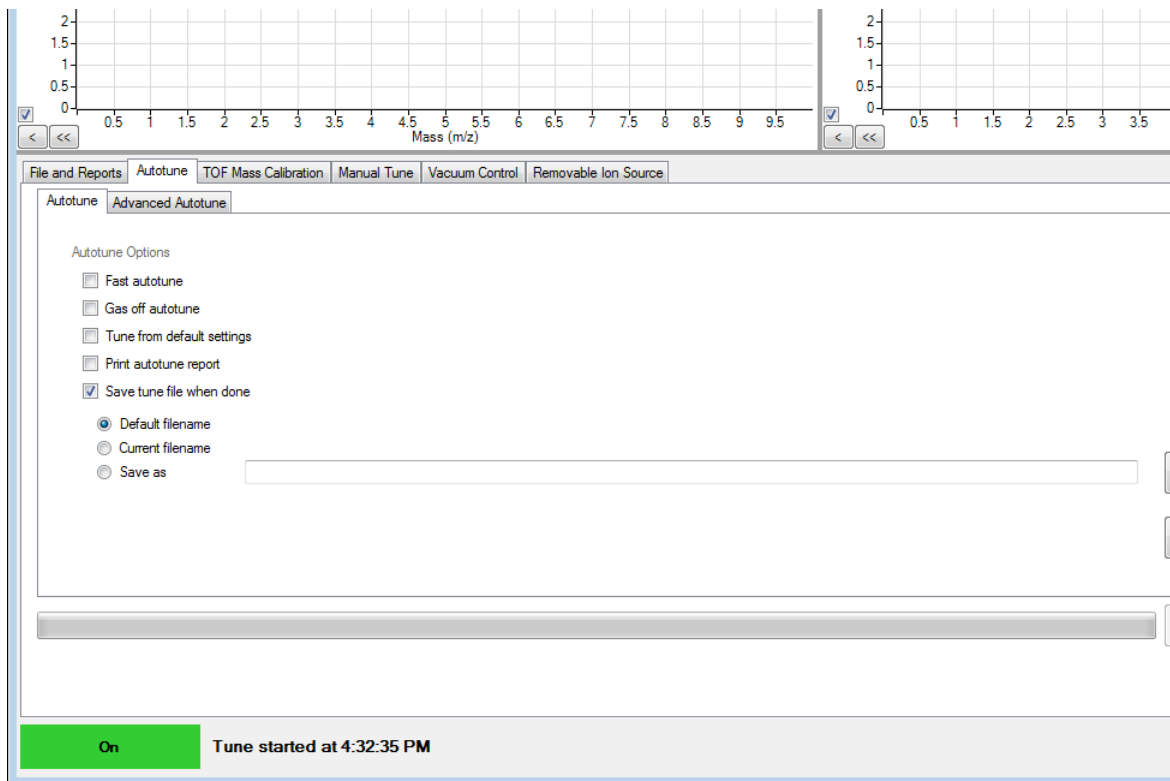

Figure 12 EI Autotune

To Remove the Upper RIS Cover



The upper RIS cover is in front of the instrument ([Figure 13](#)). Remove it to access the latches on the analyzer cover, attach the RIS probe, or access the EI calibration vial. Do not remove the upper RIS cover for any other reasons.

Procedure

- 1 Grasp the cover by the outside corners.
- 2 Pull the cover straight up, and remove it from the instrument.

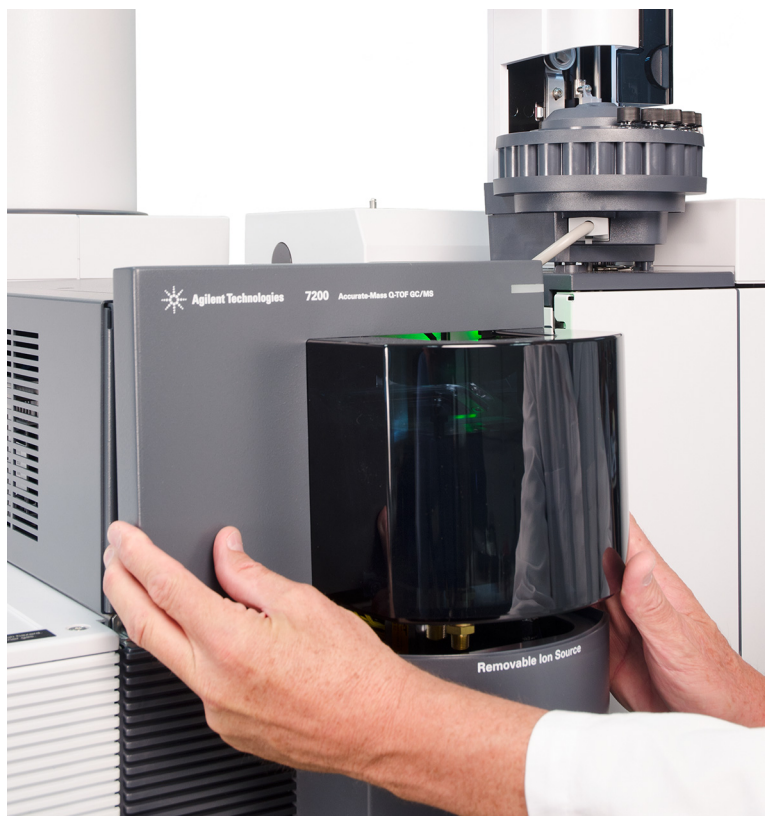

Figure 13 Upper RIS cover

To Open the Analyzer Cover for Access to the Analyzer Sideplate



Open the analyzer cover (Figure 14) to access the analyzer sideplate only. This is necessary during pump down or to access the analyzer sideplate thumbscrews. You should not open the analyzer cover for any other reason.

Procedure

- 1 Remove the upper RIS cover to expose the analyzer cover latches. See “To Remove the Upper RIS Cover” on page 52.
- 2 Open the latches on the analyzer cover at the front of the instrument.
- 3 Swing the analyzer cover open.

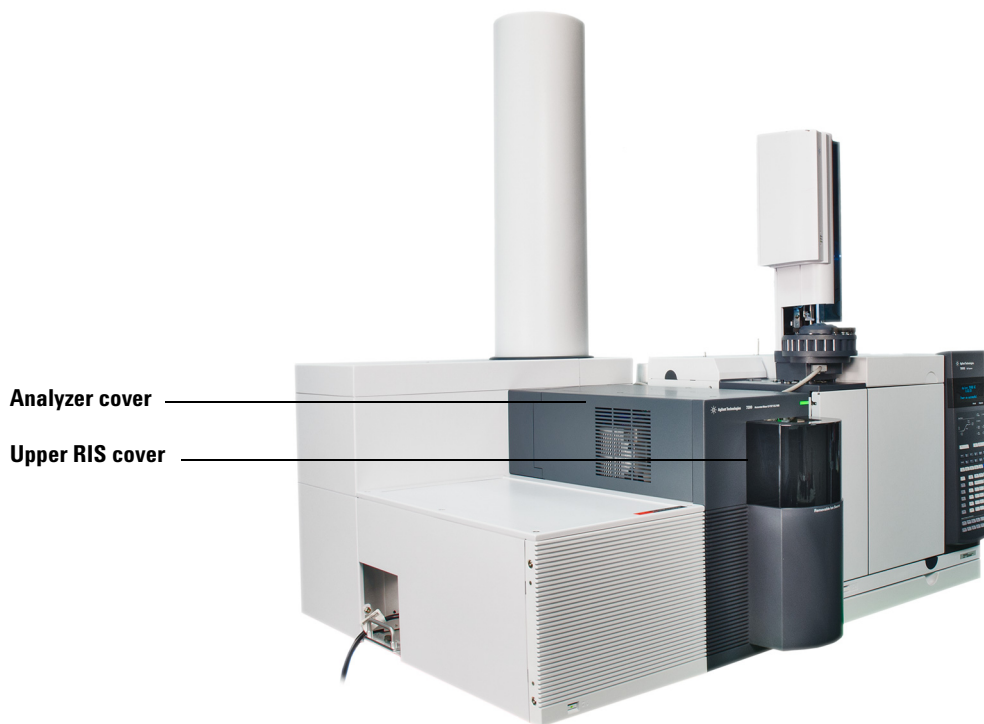

Figure 14 Covers

To Pump Down the MS

WARNING

Ensure your MS meets all the conditions listed in the introduction to this chapter before starting up and pumping down the MS. Failure to do so can result in personal injury.

WARNING

The use of hydrogen gas is specifically prohibited with this product.

WARNING

Dangerous voltages exist inside the analyzer chamber, which can result in fatal injury. Do not open the analyzer chamber door for any reason. If access is ever required, trained service personnel must first disconnect the instrument from the building power source.

Procedure

- 1 Open the analyzer cover to access the analyzer quad driver board. See [“To Open the Analyzer Cover for Access to the Analyzer Sideplate”](#) on page 53.
- 2 Plug the power cord into a grounded electrical outlet.
- 3 Turn on the Q-TOF power switch ([Figure 14](#)).
- 4 Press lightly on the metal box on the quad driver board to ensure a correct seal.

CAUTION

Do not push on the filament board safety cover while pressing on the analyzer board. This cover was not designed to withstand this type of pressure.

The foreline pump will make a gurgling noise. This noise should stop within a minute. If the noise continues, there is a *large* air leak in your system, probably at the sideplate seal or the interface column nut.

- 5 Start the MassHunter Data Acquisition program. If the Q-TOF was configured for both an EI and a CI ion source, you are prompted for the ion source type that is currently installed. Click on an EI or CI ion source type if prompted.
- 6 Select the **MS Tune** icon from the **Instrument Control** panel.
- 7 Select the **Vacuum Control** tab.

8 Click the **Pumpdown** button.

Figure 15 Vacuum Control tab

CAUTION

Do not turn on any GC heated zones until carrier gas flow is on. Heating a column with no carrier gas flow will damage the column.

Within 10 to 15 minutes, the turbo pump speed should be up to 80% (Figure 15). The pump speed should eventually reach 95%. If these conditions are not met, the MS electronics will shut off the foreline pump. In order to recover from this condition, you must power cycle the MS. If the MS does not pump down correctly, see the manual or online help for information on troubleshooting air leaks and other vacuum problems.

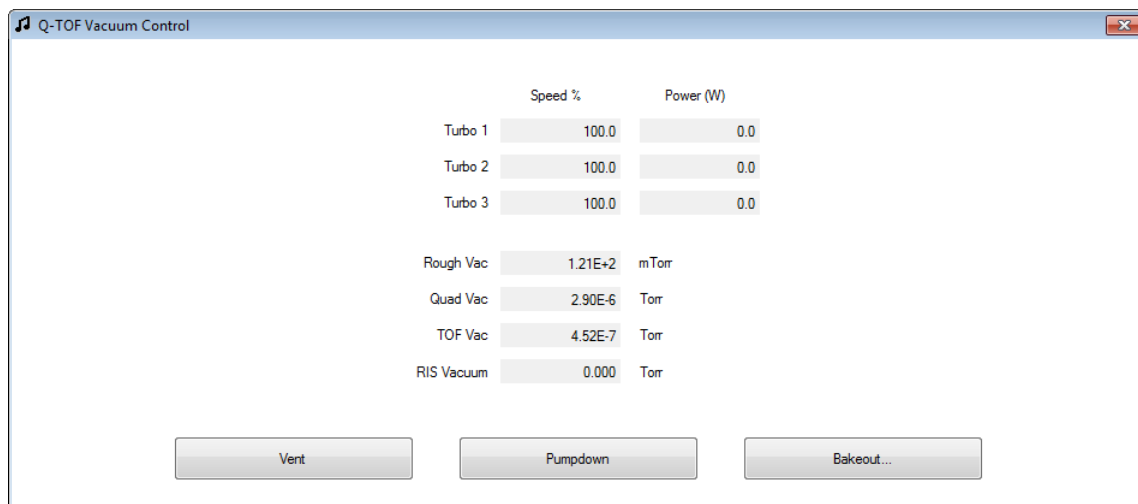
- 9 Turn on the carrier gas flow after the vacuum pumps have been running for 15 minutes.
- 10 When prompted, turn on the GC/MS interface heater and GC oven. Click **OK** when you have done so. The software will turn on the ion source and mass filter (quad) heater. The temperature setpoints are stored in the current autotune file.
- 11 After the message **Okay to run** appears, wait 2 hours for the MS to reach thermal equilibrium. Data acquired before the MS has reached thermal equilibrium may not be reproducible.
- 12 Tune the MS. (See “[To Autotune the MS for EI Mode](#)” on page 50 or “[To Perform a CI Autotune](#)” on page 72.)

To Vent the MS

Procedure

- 1 Click the **MS Tune** icon from the **Instrument Control** panel.
- 2 Select the **Vacuum Control** tab. See [Figure 15](#).
- 3 Set the GC/MS interface heater and the GC oven temperatures to ambient (room temperature).
- 4 When the GC temperatures have reached 30 °C, turn off the flow of carrier gas.
- 5 Click the **Vent** button.

WARNING

The use of hydrogen gas is specifically prohibited with this product.

CAUTION

Be sure the GC oven and the GC/MS interface are cool before turning off carrier gas flow.

- 6 Turn off the MS by pressing the power switch. (See [Figure 1](#).)
- 7 Unplug the MS power cord.

WARNING

Allow the analyzer to cool to near room temperature before touching it.

CAUTION

When the MS is vented, do not put the Workstation into Instrument Control view. Doing so will turn on the interface heater, which can damage the column.



4 Operating in Chemical Ionization (CI) Mode

Setting Up Your MS to Operate in CI Mode	58
The GC/MS Interface	59
Operating the CI MS	61
High Vacuum Pressure in CI Mode	62
Other Reagent Gases	63
CI Autotune	65
The Flow Control Module	66
To Switch from the EI Mode to CI Mode	67
To Operate the Reagent Gas Flow Control Module	69
To Set a Reagent Gas Flow	71
To Perform a CI Autotune	72

This chapter provides information and instructions for operating the 7200 Q-TOF GC/MS system in Chemical Ionization (CI) mode. Most of the information in the preceding chapter is also relevant.

Most of the material is related to methane chemical ionization but one section discusses the use of other reagent gases.

The software contains instructions for setting the reagent gas flow and for performing CI autotunes. Autotunes are provided for positive CI (PCI) with methane reagent gas and for negative CI (NCI) with any reagent gas.



Setting Up Your MS to Operate in CI Mode

Setting up your MS for operation in CI mode requires special care to avoid contamination and air leaks.

- Always use the highest purity methane (and other reagent gases, if applicable). Methane must be at least 99.9995% pure.
- Always verify the MS is performing well in EI mode before switching to CI.
- Ensure the CI ion source is installed.
- Ensure the reagent gas plumbing has no air leaks. This is determined in PCI mode, checking for m/z 32 after the methane pretune.
- Ensure the reagent gas inlet line is equipped with gas purifiers (not applicable for ammonia).

The GC/MS Interface

The GC/MS interface ([Figure 16](#)) is a heated conduit into the MS for the capillary column. It is bolted onto the right side of the analyzer chamber, with an O-ring seal and has a protective insulated cover which should be left in place.

One end of the interface passes through the side of the GC and extends into the oven. It is threaded to allow connection of the column with a nut and ferrule. The other end of the interface fits into the ion source. The last 4 to 5 mm of the capillary column extend past the end of the guide tube and into the ionization chamber. When changing the removable ion source, the interface is automatically retracted from the ion source with the MassHunter software. This allows the source to slide freely in and out of the analyzer chamber.

For CI operating mode, reagent gas is also plumbed into the interface. A tip seal keeps reagent gases from leaking out around the tip. The reagent gas enters the interface body and mixes with carrier gas and sample in the ion source.

The GC/MS interface is heated by an electric cartridge heater. Normally, the heater is powered and controlled by the Thermal Aux #2 heated zone of the GC. The interface temperature can be set from the MassHunter Workstation or from the gas chromatograph keypad. A sensor (thermocouple) in the interface monitors the temperature.

This interface is also be used for EI operation.

The interface should be operated in the 250 ° to 350 °C range. Subject to that restriction, the interface temperature should be slightly higher than the maximum GC oven temperature, but never higher than the maximum column temperature.

See Also

[“To Install a Capillary Column in the GC/MS Interface”](#) on page 30.

4 Operating in Chemical Ionization (CI) Mode

CAUTION

Never exceed the maximum column temperature, either in the GC/MS interface, the GC oven, or the inlet.

WARNING

The GC/MS interface operates at high temperatures. If you touch it when it is hot, it will burn you.

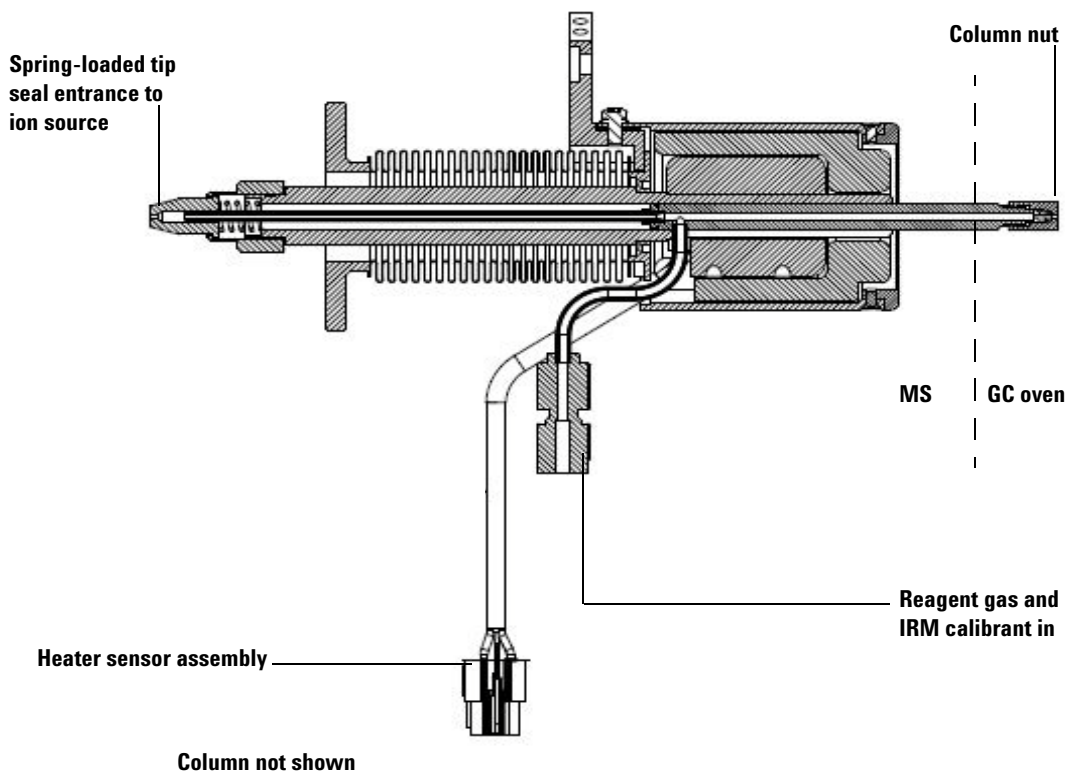

Figure 16 The GC/MS interface

Operating the CI MS

Operating your GC/MS in the CI mode is slightly more complicated than operating in the EI mode. After tuning, gas flow, temperatures (Table 5), and electron energy may need to be optimized for your specific analyte.

Table 5 Temperatures for CI operation

	Ion source	Analyzer	GC/MS interface
PCI	300 °C	150 °C	280 °C
NCI	150 °C	150 °C	280 °C

Start the system in CI mode

When starting up the system you may begin in either PCI or NCI mode. Depending upon the application, use the following reagent gas flowrates during system startup:

- PCI mode set reagent gas flow to 20 (1 mL/min)
- NCI mode set reagent gas flow to 40 (2 mL/min)

High Vacuum Pressure in CI Mode

The largest influences on operating pressure in CI mode are the reagent and collision cell gas flows. [Table 6](#) lists typical pressures for various reagent gas flows, depending upon the collision cell gas flowrate. Familiarize yourself with the measurements on your system under operating conditions and watch for changes that may indicate a vacuum or gas flow problem. Measurements will vary by as much as 30% from one MS to the next.

Analyzer vacuum with reagent gas flowing

Note that the mass flow controller (MFC) is calibrated for methane and the vacuum gauge is calibrated for nitrogen, so these measurements are not accurate, but are intended as a guide to typical observed readings ([Table 6](#)). They were taken with the following set of conditions. Note that these are typical PCI temperatures:

Source temperature	230 °C
Quad temperature	150 °C
Interface temperature	280 °C
Inlet	250 °C
Oven	100 °C
Helium carrier gas flow	1 mL/min

Table 6 Typical analyzer vacuum with reagent gas flow

MFC (%)	Collision cell gas flow on N ₂ = 1.5 mL/min			Collision cell gas flow off N ₂ = 0 mL/min		
	Rough Pump (mTorr)	Quadrupole (Torr)	Flight Tube (Torr)	Rough Pump (mTorr)	Quadrupole (Torr)	Flight Tube (Torr)
0	1.36e+02	3.62e-05	3.35e-07	9.13e+01	5.98e-07	1.64e-07
10	1.36+02	3.62e-05	3.37e-07	1.14e+01	1.27e-06	1.65e-07
15	1.43+02	3.66e-05	3.37e-07	1.23e+01	1.62e-06	1.67e-07
20	1.5+02	3.71e-05	3.39e-07	1.31e+01	1.96e-06	1.67e-07
25	1.57+02	3.73e-05	3.41e-07	1.39e+01	2.32e-06	1.70e-07
30	1.63+02	3.77e-05	3.41e-07	1.46e+01	2.64e-06	1.71e-07
35	1.69+02	3.81e-05	3.41e-07	1.52e+01	3.00e-06	1.71e-07
40	1.74+02	3.83e-05	3.43e-07	1.58e+01	3.34e-06	1.72e-07

Other Reagent Gases

This section describes the use of isobutane or ammonia as the reagent gas. You should be familiar with operating the CI-equipped 7200 Q-TOF GC/MS with methane reagent gas before attempting to use other reagent gases.

CAUTION

Do not use nitrous oxide as a reagent gas. It radically shortens the life span of the filament.

Changing the reagent gas from methane to either isobutane or ammonia changes the chemistry of the ionization process and yields different ions. The principal chemical ionization reactions encountered are described in general in the *Agilent 7200 Accurate-Mass Q-TOF GC/MS Concept Guide*. If you are not experienced with chemical ionization, we suggest reviewing that material before you proceed.

Isobutane CI

Isobutane (C₄H₁₀) is commonly used for chemical ionization when less fragmentation is desired in the chemical ionization spectrum. This is because the proton affinity of isobutane is higher than that of methane; hence less energy is transferred in the ionization reaction.

Addition and proton transfer are the ionization mechanisms most often associated with isobutane. The sample itself influences which mechanism dominates.

Ammonia CI

Ammonia (NH₃) is commonly used for chemical ionization when less fragmentation is desired in the chemical ionization spectrum. This is because the proton affinity of ammonia is higher than that of methane; hence less energy is transferred in the ionization reaction.

Because many compounds of interest have insufficient proton affinities, ammonia chemical-ionization spectra often result from the addition of NH₄⁺ and then, in some cases, from the subsequent loss of water. Ammonia reagent ion spectra have principal ions at *m/z* 18, 35, and 52, corresponding to NH₄⁺, NH₄(NH₃)⁺, and NH₄(NH₃)₂⁺.

CAUTION

Use of ammonia affects the maintenance requirements of the MS. See [Chapter 6](#), "General Maintenance" for more information.

CAUTION

The pressure of the ammonia supply must be less than 5 psig. Higher pressures can result in ammonia condensing from a gas to a liquid.

Always keep the ammonia tank in an upright position, below the level of the flow module. Coil the ammonia supply tubing into several vertical loops by wrapping the tubing around a can or bottle. This will help keep any liquid ammonia out of the flow module.

Ammonia tends to break down vacuum pump fluids and seals. Ammonia CI makes more frequent vacuum system maintenance necessary. (See the *Agilent 7200 Q-TOF GC/MS Troubleshooting and Maintenance Manual*.)

CAUTION

When running ammonia for 5 or more hours a day, the foreline pump must be ballasted (flushed with air) for at least 1 hour a day to minimize damage to pump seals. Always purge the MS with methane after flowing ammonia.

Frequently, a mixture of 5% ammonia and 95% helium or 5% ammonia and 95% methane is used as a CI reagent gas. This is enough ammonia to achieve good chemical ionization while minimizing its negative effects.

Carbon dioxide CI

Carbon dioxide is often used as a reagent gas for CI. It has obvious advantages of availability and safety.

CI Autotune

After the reagent gas flow is set, the lenses and electronics of the MS should be tuned which is a good starting point for developing your application settings. Typical CI application settings are shown in [Table 7](#).

Perfluoro-5,8-dimethyl-3,6,9-trioxidodecane (PFDTD) is used as the calibrant. Instead of flooding the entire vacuum chamber, the PFDTD is introduced directly into the ionization chamber through the GC/MS interface by means of the gas flow control module. There are no tune performance criteria. If CI autotune completes, it passes.

CAUTION

Always verify MS performance in EI before switching to CI operation.

Table 7 Typical CI application settings

Parameter	Methane		Isobutane		Ammonia		EI
	Positive	Negative	Positive	Negative	Positive	Negative	
Ion polarity	Positive	Negative	Positive	Negative	Positive	Negative	N/A
Emission	150 μ A	50 μ A	150 μ A	50 μ A	150 μ A	50 μ A	35 μ A
Electron energy	150 eV	150 eV	150 eV	150 eV	150 eV	150 eV	70 eV
Filament	1	1	1	1	1	1	1 or 2
Repeller	3 V	3 V	3 V	3 V	3 V	3 V	30 V
Ion focus	130 V	130 V	130 V	130 V	130 V	130 V	90 V
Entrance lens offset	20 V	20 V	20 V	20 V	20 V	20 V	25 V
Shutoff valve	Open	Open	Open	Open	Open	Open	Closed
Suggested flow	20%	40%	20%	40%	20%	40%	N/A
Source temp	250 $^{\circ}$ C	150 $^{\circ}$ C	250 $^{\circ}$ C	150 $^{\circ}$ C	250 $^{\circ}$ C	150 $^{\circ}$ C	230 $^{\circ}$ C
Quad temp	150 $^{\circ}$ C	150 $^{\circ}$ C	150 $^{\circ}$ C	150 $^{\circ}$ C	150 $^{\circ}$ C	150 $^{\circ}$ C	150 $^{\circ}$ C
Interface temp	280 $^{\circ}$ C	280 $^{\circ}$ C	280 $^{\circ}$ C	280 $^{\circ}$ C	280 $^{\circ}$ C	280 $^{\circ}$ C	280 $^{\circ}$ C
Autotune	Yes	Yes	No	Yes	No	Yes	Yes

N/A Not available

The Flow Control Module

The CI reagent gas flow control module regulates the flow of reagent gas into the CI GC/MS interface. The flow module consists of a mass flow controller (MFC), gas select valves, CI calibration valve, shutoff valve, control electronics, and plumbing.

The instrument provides Swagelok inlet fittings for connecting the CI reagent gas. The software refers to it as CI reagent gas. Supply reagent gases at 20 to 25 psi (138 to 172 kPa) for Methane.

To Switch from the EI Mode to CI Mode

CAUTION

Always verify GC/MS performance in EI before switching to CI operation.

CAUTION

Always wear clean gloves while touching the analyzer or any other parts that go inside the analyzer chamber.

Procedure

- 1 Change the source. See “To Change the Ion Source” on page 78.
- 2 Load a suitable PCI or NCI method for use with the CI source.
- 3 Click the **MS Tune** icon in the **Instrument Control** panel to display the **Tune** dialog box and select the **Autotune** tab.

The method selects PCI or NCI autotune and the correct reagent gas.
- 4 Select the **Tune from default settings** check box because you have changed the ion source.
- 5 Select **Print autotune report** check box to automatically print a tune report.
- 6 Click the **Autotune** button to start the autotune. At the completion of the autotune, a Tune Report is printed.
- 7 Review the Tune Report. If the results are acceptable, save the autotune by clicking the **Files and Report** tab, then click the **Save** button.

Table 8 Default Tune Control Limits, used by CI autotune only

Reagent gas	Methane		Ammonia	
	Positive	Negative	Positive	Negative
Abundance target	1x10 ⁶	1x10 ⁶	N/A	1x10 ⁶
Peakwidth target	0.7	0.7	N/A	0.7
Maximum repeller	4	4	N/A	4

4 Operating in Chemical Ionization (CI) Mode

Table 8 Default Tune Control Limits, used by CI autotune only (continued)

Reagent gas		Methane		Ammonia
Maximum emission current, μA	240	50	N/A	50
Max electron energy, eV	240	240	N/A	240

Notes for Table 8:

- **N/A** Not available.
- **Abundance target** Adjust higher or lower to get desired signal abundance. Higher signal abundance also gives higher noise abundance.
- **Peakwidth target** Higher peakwidth values give better sensitivity, lower values give better resolution.
- **Maximum emission current** Optimum emission current maximum for NCI is very compound-specific and must be selected empirically. Optimum emission current for pesticides, for example, may be about 200 μA .

To Operate the Reagent Gas Flow Control Module

Procedure

- 1 In **Instrument Control** panel, select the **MS Tune** icon to display the **GC/Q-TOF Tune** dialog box. Select the **Manual Tune** tab then select the **Ion Source** tab to display the ion source parameters.

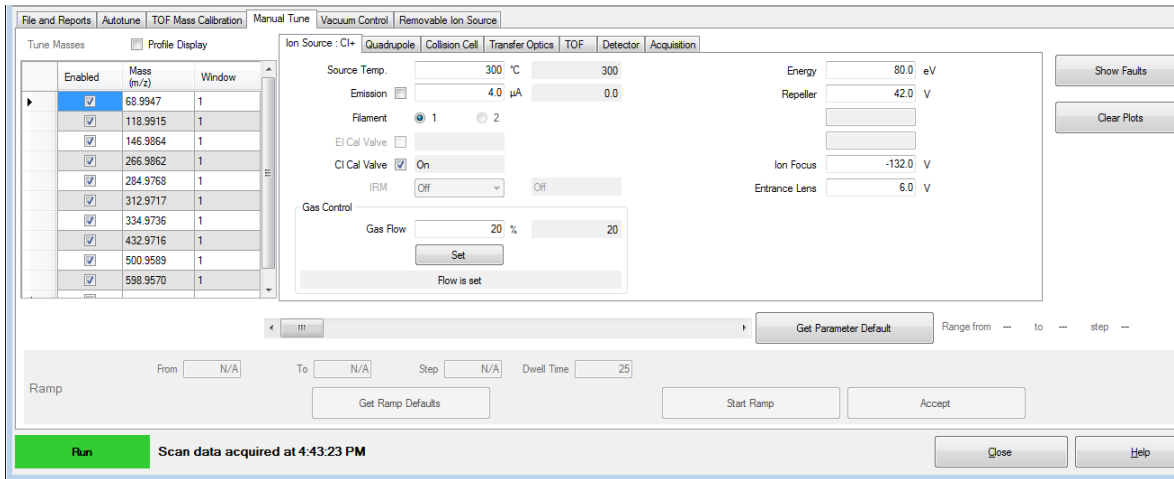

Figure 17 CI flow control

4 Operating in Chemical Ionization (CI) Mode

- 2 Use the parameters in the **CI Reagent Gas Control** area to control reagent gas flow.

CI Reagent - Selects the reagent gas from the dropdown menu.

CI Gas Flow - Enter percent of maximum volumetric flow for the selected reagent gas. The actual % transmitted by the flow controller is shown next to this entry. 20% is a good value for PCI and 40% is a good value for NCI.

Set button - Opens the selected reagent gas supply valve and controls the reagent gas flow to the entered setpoint.

Off button - Turns off the reagent gas flow.

Purge button - Opens the selected reagent gas valve for 6 minutes to clear the system of unwanted compounds.

Pumpout button - Closes the reagent gas valve for 4 minutes and evacuates the system of reagent gases. At the end of the pumpout time the selected reagent gas valve opens.

To Set a Reagent Gas Flow

CAUTION

After the system has been switched from EI to CI mode, or vented for any other reason, the MS must be baked out for at least 2 hours before tuning.

CAUTION

Continuing with CI autotune if the MS has an air leak or large amounts of water will result in *severe* ion source contamination. If this happens, you will need to *vent the MS* and *clean the ion source*.

Procedure

- 1 In **Instrument Control** panel, select the **MS Tune** icon to display the **GC/Q-TOF Tune** dialog box. Select the **Manual Tune** tab then select the **Ion Source** tab to display the ion source parameters.
- 2 In the **CI Reagent Gas Control** area, select the CI reagent gas you are using.
- 3 Enter the reagent gas flow setpoint in the **CI Gas Flow** field. This value is entered as a percentage of maximum flow rate. The recommended flow is 20% for a PCI source and 40% for an NCI source.
- 4 Click the **Set** button. The **Flow Set** indication is displayed.

The reagent gas is flowing into the ion source at the rate displayed next to the setpoint.
- 5 Click the **Files and Reports** tab, then click the **Save** button to save your changes to the currently loaded tune file.

To Perform a CI Autotune

CAUTION

Always verify MS performance in EI before switching to CI operation.

CAUTION

Avoid tuning more often than is absolutely necessary; this will minimize PFDTD background noise and help prevent ion source contamination.

Procedure

- 1 Verify that the MS performs correctly in EI mode first.
- 2 Click the **MS Tune** icon in the **Instrument Control** panel to display the **GC/Q-TOF Tune** dialog box.
- 3 If necessary, load a new tune file by clicking on the **Files and Report** tab then click the **Load** button in the **Tune File** area. Select a tune file and click the **OK** button.

The tune file must match the type of ion source in the analyzer. For a CI ion source select a tune file created for a positive or negative CI source.

- 4 Click the **Autotune** tab and select **PCI source** for a positive CI source or **NCI source** for a negative CI source.
- 5 Select the reagent gas you are using from the dropdown menu in the **CI Reagent Gas** area.
- 6 If a log file and associated data files of the tune are required, click the **Files and Reports** tab and in the **Log Files** section, click on the **Browse** button to create a directory and files for the logs. Click on the required log and data files check boxes.
- 7 Click on the **Manual Tune** tab and select the **Ion source** tab. In the **CI Reagent Gas** section, select the reagent gas and then enter a **CI Gas Flow** rate of 20% for a PCI source or 40% for an NCI source. Click on the **Autotune** tab to return to Autotune.
- 8 Select the **Tune from default settings** check box if you are restarting the system after a system vent, major servicing, or a power outage. If you clear

the **Tune from default settings** box, the Autotune process starts using previous tune values.

- 9 Select **Save tune file when done** check box to save the new tune parameters generated by the autotune. Do not select this item if you want to review the autotune report before saving the newly generated tune parameters.
- 10 Select the **Print autotune report** check box to automatically print a tune report.
- 11 Click the **Autotune** button to start the autotune. The Status line displays the current step in the autotune process and the plot of the tuned parameter for that step is shown in the top graph. If specified above, at the completion of the autotune a Tune Report is printed.

To stop the autotune before it completes the autotune parameter selection, click the **Abort Autotune** button. The parameters from the last successful autotune are used.

- 12 Review the Tune Report. If the results are acceptable and you did not select the **Save tune file when done** check box, save the autotune by clicking the **Files and Report** tab, then click the **Save** button.

4 Operating in Chemical Ionization (CI) Mode

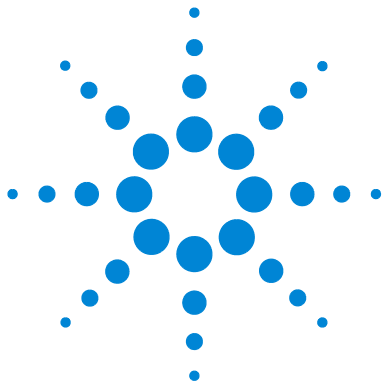

5 Using the Removable Ion Source

- The Removable Ion Source [76](#)
- To Change the Ion Source [78](#)
- To Install the RIS Probe Extraction Tool [80](#)
- To Remove the Source from the Analyzer Chamber [82](#)
- To Change the Ion Source on the RIS Probe Extraction Tool [84](#)
- To Install the Ion Source in the Analyzer Chamber [86](#)
- To Remove the RIS Probe Extraction Tool from the Instrument [87](#)

This chapter will explain how to use the features of the removable ion source.



The Removable Ion Source

The removable ion source (RIS) is a feature of the Agilent 7200 Q-TOF GC/MS that allows changing of the ion source without venting the instrument through the use of the RIS probe extractor tool. The source must be removed from the MS periodically for routine cleaning and maintenance, or for changing ionization modes, and the new RIS minimizes the downtime necessary to complete these tasks. This process is guided by the MassHunter Workstation software, which performs the purging, valve operation, and pump down steps automatically.

The RIS probe extraction tool consists of a RIS bayonet that attaches to the source, a handle for moving the source in and out of the instrument, and a cooling chamber for cooling the source prior to removal (Figure 18). The entire process is guided by the MassHunter Workstation Software.

The RIS cooling chamber is attached to the instrument to provide a place to vent and purge the source with nitrogen during source changing. An automatic gate valve closes off the cooling chamber from the instrument to eliminate the need for venting the instrument during this process. Only the small RIS cooling chamber is vented.

CAUTION

The software and firmware are revised periodically. If the steps in these procedures do not match your MassHunter Workstation software, refer to the manuals and online help supplied with the software for more information.

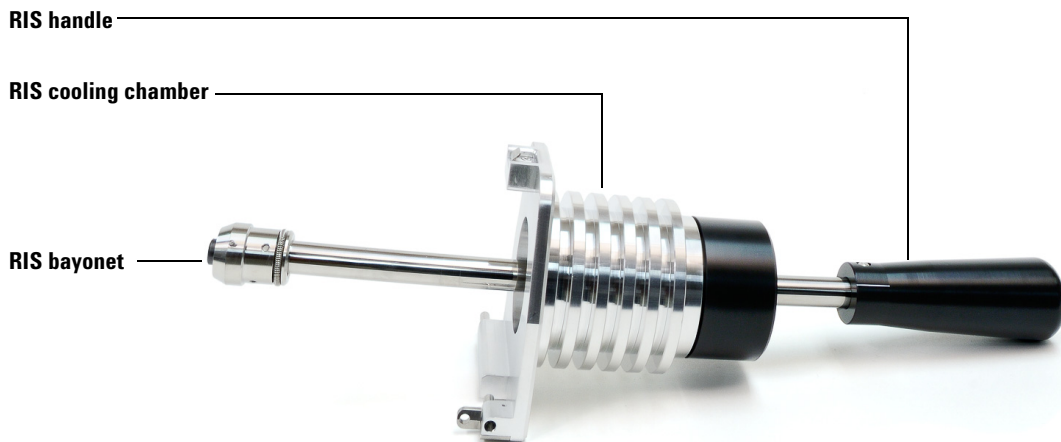

Figure 18 RIS probe extraction tool

To Change the Ion Source

The steps necessary for changing the ion source are provided here and also interactively in the MassHunter Workstation software. The process is mostly automated, with the exception of the use of the RIS probe extraction tool to remove and install the ion source. Purging the chamber, cooling the source, and pumping down are all performed with the use of the Workstation software.



Procedure

- 1 From MassHunter Data Acquisition software control view, click the **MS Tune** icon to display the **GC/Q-TOF Tune** dialog box.
- 2 Click the **Removable Ion Source** tab in the **GC/Q-TOF Tune** screen. (Figure 19)

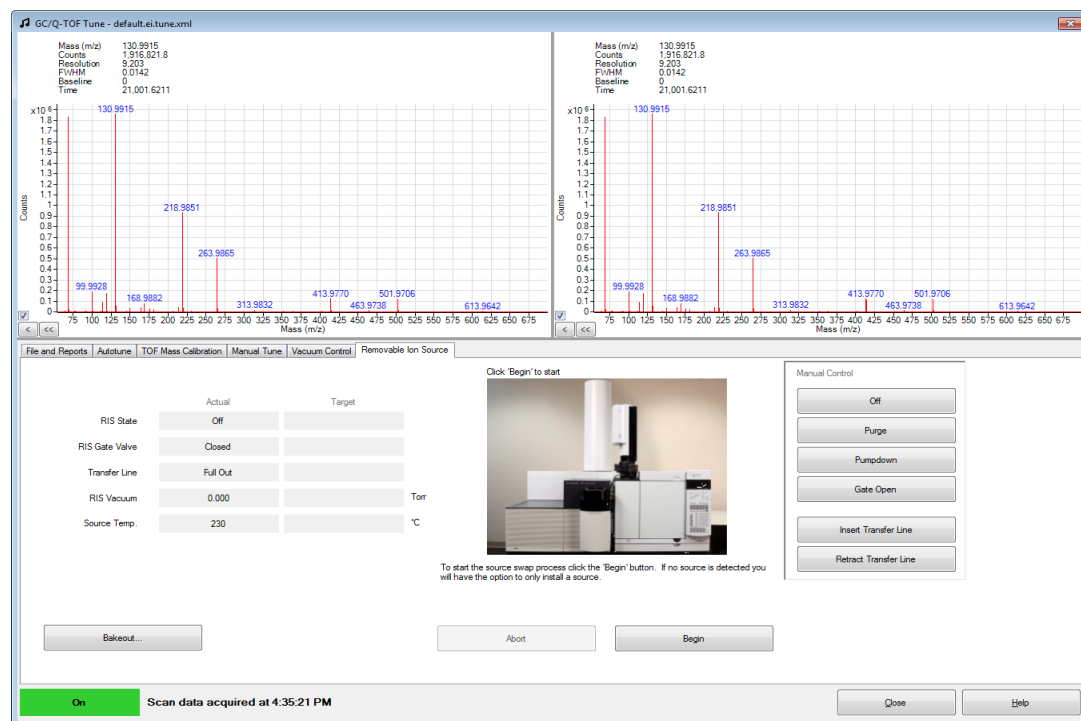

Figure 19 GC/Q-TOF Tune dialog box

- 3 Click the **Begin** button to purge the instrument.
- 4 When prompted, remove the RIS chamber door and attach the RIS probe extraction tool. See [“To Install the RIS Probe Extraction Tool”](#) on page 80.
- 5 Click **Next** to purge the chamber and pump down.
- 6 When the system is ready for source removal, click **Next** to retract the transfer line and open the gate valve.

The RIS status area will note when the **Gate Valve** is **Open** and the **Transfer Line** is **Full Out**.

- 7 When prompted, remove the source. See [“To Remove the Source from the Analyzer Chamber”](#) on page 82.
- 8 Once the source is retracted fully into the chamber, click **Next** to close the gate valve and purge the cooling chamber. The purge takes approximately 10 minutes.
- 9 When prompted, open the cooling chamber and change the ion source. See [“To Change the Ion Source on the RIS Probe Extraction Tool”](#) on page 84.
- 10 After replacing the source and securing the cooling chamber door, click **Next** to purge and pump down.
- 11 When prompted that the system is ready for source installation, click **Next** to retract the transfer line and open the gate valve.
- 12 When prompted, install the ion source in the analyzer chamber. See [“To Install the Ion Source in the Analyzer Chamber”](#) on page 86.
- 13 Verify in the RIS **Status** that the ion source temperature readback shows a source temperature. This ensures that the source is fully inserted into its socket.

CAUTION

If the ion source is not fully installed, it may interfere with the gate valve as it closes. Damage to the RIS, the valve, or the transfer line may occur.

- 14 Click **Next** to close the gate valve and vent the RIS cooling chamber.
- 15 Remove the RIS probe extraction tool and replace the RIS chamber cover. See [“To Remove the RIS Probe Extraction Tool from the Instrument”](#) on page 87.
- 16 Click **Next** to pump down the chamber behind the RIS chamber cover.
- 17 When prompted, click **Finish**.

To Install the RIS Probe Extraction Tool



This procedure is part of an automated series of steps controlled by MassHunter. Do not attempt this procedure unless prompted by MassHunter to remove the RIS cover door.

Procedure

- 1 When prompted by MassHunter, remove the upper RIS cover (see [“To Remove the Upper RIS Cover”](#) on page 52).
- 2 Open the latch on the right side of the RIS cover door.
- 3 Swing the door open.
- 4 Lift the RIS cover door straight up to free it from the hinges, and remove.

CAUTION

Do not leave the instrument with the RIS cover off. If you remove the cover, you must install the RIS probe as soon as possible to minimize contamination in the instrument.

- 5 Holding the RIS probe extraction tool by the handle, position the RIS cooling chamber up against the instrument RIS chamber. Hold the handle perpendicular to the front of the instrument so that the outside edge of the cooling chamber is flush with the RIS chamber opening on the front instrument.
- 6 Line up the pins on the probe hinge with the slots on the instrument hinge.
- 7 Lower the pins into the hinge.
- 8 Close the cooling chamber door, and secure the door with the latch on the right side.
- 9 Return to [step 5](#) in the [“To Change the Ion Source”](#) on page 78.

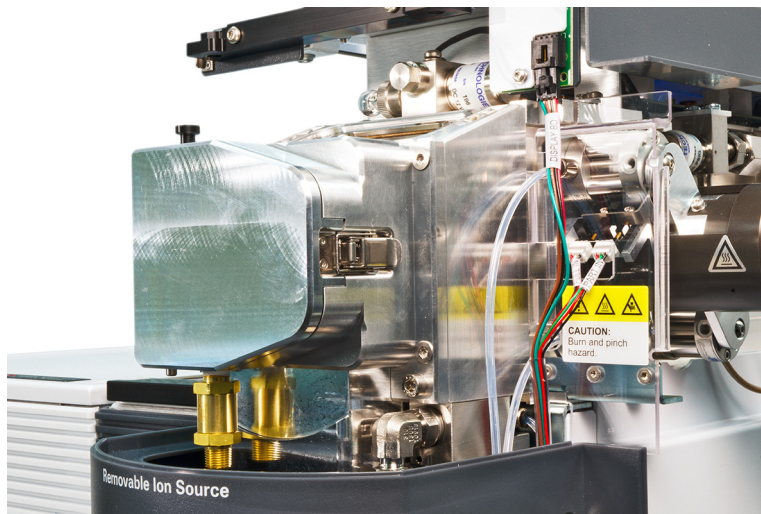

Figure 20 RIS cover door

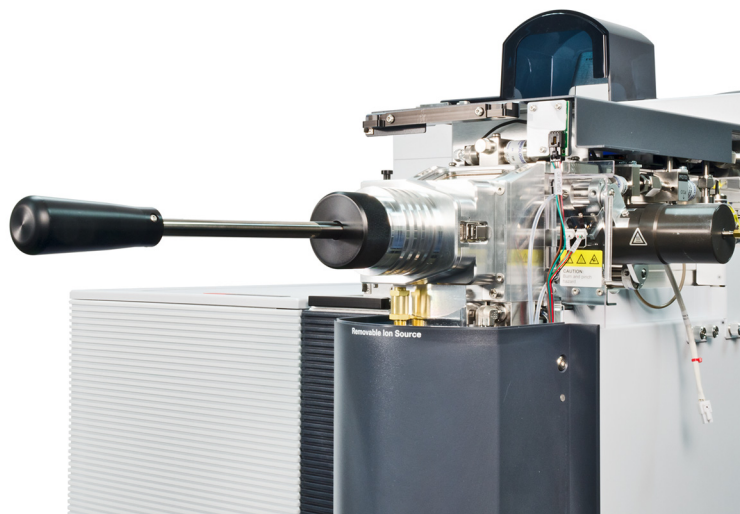

Figure 21 RIS probe installed

To Remove the Source from the Analyzer Chamber

This procedure is part of an automated series of steps controlled by MassHunter. Do not attempt this procedure unless prompted by MassHunter. The RIS **Status** area on the **GC/Q-TOF Tune** tab must show the **Gate Valve** is **Open** and the **Transfer Line** is **Full Out**.

Procedure



- 1 Holding the RIS handle, turn the alignment guide, which is the white line on the RIS handle, to the 2 o'clock position from the top of the handle. This ensures that the RIS bayonet is aligned properly to attach to the source.

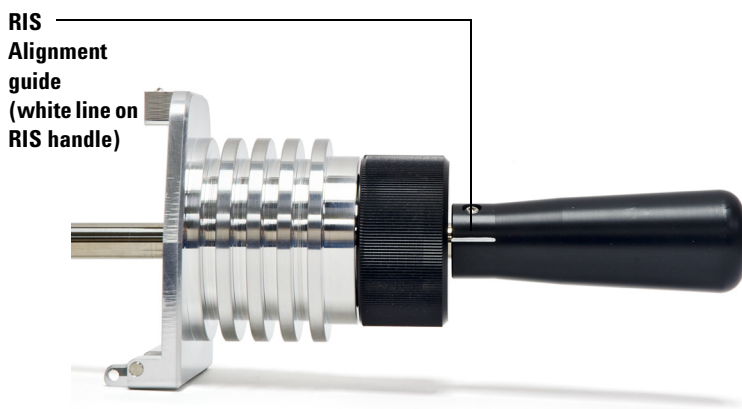

Figure 22 RIS Alignment guide

CAUTION

While the RIS handle is fully extended, do not bump or push it from the side. Doing so will break the seal and allow air into the cooling chamber.

CAUTION

Do not try to guide the ion source in manually. Push the RIS handle gently and allow the RIS bayonet to slide on its own. The RIS bayonet will slide in straight if it is allowed to move naturally.

- 2 Keeping the RIS handle in position, push the RIS handle gently and allow the RIS bayonet to extend into the analyzer chamber. Ensure the RIS handle extends fully, to ensure that the RIS bayonet seats in the holes on the ion source body properly.
- 3 When the ion source is properly seated, turn the RIS handle counter clockwise until the alignment guide is in the 12 o'clock position, to lock the ion source in place.
- 4 Pull the RIS handle toward you, keeping the alignment guide at the 12 o'clock position, to retract the ion source into the RIS cooling chamber.
- 5 Return to [step 8](#) in the “To Change the Ion Source” on page 78.

To Change the Ion Source on the RIS Probe Extraction Tool

This procedure is part of an automated series of steps controlled by MassHunter. Do not attempt this procedure unless prompted by MassHunter. The RIS **Status** area on the **GC/Q-TOF Tune** tab must show the **Gate Valve is Open** and the **RIS vacuum as 0.000 Torr**.

CAUTION

If not done correctly, source maintenance can introduce contaminants into the MS. Always wear clean rubber gloves when handling the source.



- 1 Undo the latch on the right edge of the RIS cooling chamber.
- 2 Swing open the RIS cooling chamber until the RIS handle is parallel with the front of the instrument.
- 3 Lock the RIS cooling chamber in the open position by opening it enough to engage the locking pin on the hinge.

WARNING

The 7200 Q-TOF GC/MS operates at high temperatures. Ensure the source is cooled to a safe temperature before attempting to remove it from the RIS cooling chamber.

- 4 Grasp the RIS handle with one hand, and the ion source body with the other hand.
- 5 While holding the ion source steady, turn the RIS handle counter clockwise so that the alignment guide is in the 2 o'clock position. This guides the pin on the RIS bayonet out of the track on the ion source body.
- 6 Gently pull the ion source free from the RIS bayonet and set aside.
- 7 Remove the new ion source from its storage container. The ion source remains connected to the lid. Twist the lid clockwise to separate the ion source from the lid.
- 8 Turn the RIS handle so that the alignment guide is in the 2 o'clock position.
- 9 Guide the pin on the RIS bayonet into the tracks on the end of the ion source body.

- 10** While holding the ion source securely, turn the RIS handle counter clockwise so that the alignment guide is in the 12 o'clock position, to lock the ion source securely on the bayonet.
- 11** Retract the RIS handle fully so that the ion source is located completely in the cooling chamber.
- 12** Raise the locking pin on the RIS cooling chamber hinge and swing it shut.
- 13** Secure the RIS cooling chamber to the instrument with the latch on the right side of the door.
- 14** Return to [step 10](#) in the “[To Change the Ion Source](#)” on page 78.

To Install the Ion Source in the Analyzer Chamber

This procedure is part of an automated series of steps controlled by MassHunter. Do not attempt this procedure unless prompted by MassHunter. The RIS **Status** area on the **GC/Q-TOF Tune** tab must show the **Gate Valve** is **Open** and the **Transfer Line** is **Full Out**.

CAUTION

Take care when walking past the front of the instrument when the RIS handle is fully extended, to avoid damage to the instrument. When closed, the RIS handle extends 48 cm (19 inches) out from the front of the instrument.

CAUTION

Do not try to guide the ion source in manually. Push the RIS handle gently and allow the RIS bayonet to slide on its own. The RIS bayonet will slide in straight if it is allowed to move naturally.

Procedure



- 1 Ensure the alignment guide on the RIS handle is in the 12 o'clock position. Push the RIS handle gently towards the analyzer chamber and allow it to extend into the analyzer chamber. This will seat the ion source securely into its socket.
- 2 Once the RIS handle is fully extended, turn the RIS handle clockwise until the alignment guide is in the 2 o'clock position to release the ion source body from the RIS bayonet.
- 3 Pull the RIS handle toward you until it is fully retracted into the RIS cooling chamber.
- 4 Return to [step 13](#) in the “[To Change the Ion Source](#)” on page 78.

To Remove the RIS Probe Extraction Tool from the Instrument

This procedure is part of an automated series of steps controlled by MassHunter. Do not attempt this procedure unless prompted by MassHunter. The RIS **Status** area on the **GC/Q-TOF Tune** tab must show the **Gate Valve** is **Open** and the **RIS vacuum** as **0.000 Torr**.

WARNING

The 7200 Q-TOF GC/MS operates at high temperatures. Ensure the RIS cooling chamber is at a safe temperature before attempting to remove it from the instrument.



- 1 Undo the latch on the right side of the RIS probe extraction tool and open the door.
- 2 Lift the RIS probe extraction tool up to release it from its hinges.
- 3 Replace the RIS probe extraction tool with the RIS chamber door.
- 4 Line up the hinge pins on the RIS chamber door with the slots on the instrument hinge, and lower the pins into the hinge.
- 5 Swing the RIS chamber door closed and secure the door with the latch on the right side.
- 6 Return to [step 16](#) in the “[To Change the Ion Source](#)” on page 78.

5 Using the Removable Ion Source

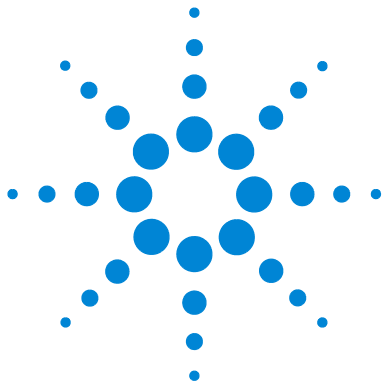

6 General Maintenance

Before Starting	90
Maintaining the Vacuum System	94
Maintaining the Analyzer	95
To Disassemble the EI Ion Source	97
To Assemble the EI Ion Source	99
To Disassemble the CI Ion Source	101
To Assemble the CI Ion Source	103
To Clean the Ion Source	105
To Remove a Filament	109
To Install a Filament	111



Before Starting

You can perform much of the maintenance required by your MS. For your safety, read all of the information in this introduction before performing any maintenance tasks.

Scheduled maintenance

Common maintenance tasks are listed in [Table 9](#). Performing these tasks when scheduled can reduce operating problems, prolong system life, and reduce overall operating costs.

Keep a record of system performance (tune reports) and maintenance operations performed. This makes it easier to identify variations from normal operation and to take corrective action.

Table 9 Maintenance schedule

Task	Every week	Every 6 months	Every year	As needed
Tune the MS				X
Check the foreline pump oil level	X			
Check the calibration vial(s)		X		
Replace the foreline pump oil*		X		
Clean the ion source				X
Check the carrier gas trap(s) on the GC and MS				X
Replace the worn out parts				X
Replace gasket on RIS probe			X	X
Check the IRM vial		X		
Replace GC gas supplies				X

* Or as needed.

Tools, spare parts, and supplies

Some of the required tools, spare parts, and supplies are included in the GC shipping kit, MS shipping kit, or MS tool kit. You must supply others yourself. Each maintenance procedure includes a list of the materials required for that procedure.

High voltage precautions

Whenever the MS is plugged in, even if the power switch is off, potentially dangerous voltage (200/240 VAC) exists on the wiring and fuses between where the power cord enters the instrument and the power switch.

When the power switch is on, potentially dangerous voltages exist on:

- Electronic circuit boards
- Toroidal transformer
- Wires and cables between the boards
- Wires and cables between the boards and the connectors on the back panel of the MS
- Some connectors on the back panel (for example, the foreline power receptacle)

Normally, all of these parts are shielded by safety covers. As long as the safety covers are in place, it should be difficult to accidentally make contact with dangerous voltages.

WARNING

Perform no maintenance with the MS turned on or plugged into its power source unless you are instructed to do so by one of the procedures in this chapter.

Some procedures in this chapter require access to the inside of the MS while the power switch is on. Do not remove any of the electronics safety covers in any of these procedures. To reduce the risk of electric shock, follow the procedures carefully.

Dangerous temperatures

Many parts in the MS operate at, or reach, temperatures high enough to cause serious burns. These parts include, but are not limited to:

- GC/MS interface
- Analyzer parts
- Vacuum pumps

WARNING

The foreline pump can cause burns if touched when operating.

WARNING

Never touch these parts while your MS is on. After the MS is turned off, give these parts enough time to cool before handling them.

WARNING

The GC/MS interface heater is powered by a thermal zone on the GC. The interface heater can be on, and at a dangerously high temperature, even though the MS is off. The GC/MS interface is well insulated. Even after it is turned off, it cools very slowly.

The GC inlets and GC oven also operate at very high temperatures. Use the same caution around these parts. See the documentation supplied with your GC for more information.

Chemical residue

Only a small portion of your sample is ionized by the ion source. The majority of any sample passes through the ion source without being ionized. It is pumped away by the vacuum system. As a result, the exhaust from the foreline pump will contain traces of the carrier gas and your samples. Exhaust from the standard foreline pump also contains tiny droplets of foreline pump oil.

An oil mist filter is supplied with the standard foreline pump. This filter stops *only* pump oil droplets. It *does not* trap any other chemicals. If you are using toxic solvents or analyzing toxic chemicals, install a hose from the mist filter outlet to the outdoors or into a fume hood vented to the outdoors. Be sure to comply with your local air quality regulations.

WARNING

The oil trap supplied with the standard foreline pump stops only foreline pump oil. It does not trap or filter out toxic chemicals. If you are using toxic solvents or analyzing toxic chemicals, use a hose to vent to a safe location.

The fluids in the foreline pump also collect traces of the samples being analyzed. All used pump fluid should be considered hazardous and handled accordingly. Dispose of used fluid as specified by your local regulations.

WARNING

When replacing pump fluid, use appropriate chemical-resistant gloves and safety glasses. Avoid all contact with the fluid.

Ion source cleaning

The main effect of operating the MS in CI mode is the need for more frequent ion source cleaning. In CI operation, the ion source chamber is subject to more rapid contamination than in EI operation because of the higher source pressures required for CI.

WARNING

Always perform any maintenance procedures using hazardous solvents under a fume hood. Be sure to operate the MS in a well-ventilated room.

Ammonia

Ammonia, used as a reagent gas, increases the need for foreline pump maintenance. Ammonia causes foreline pump oil to break down more quickly. Therefore, the oil in the standard foreline vacuum pump must be checked and replaced more frequently.

Always purge the MS with methane after using ammonia.

Be sure to install the ammonia so the tank is in an upright position. This will help prevent liquid ammonia from getting into the flow module.

Maintaining the Vacuum System

Periodic maintenance

As listed in [Table 9](#), some maintenance tasks for the vacuum system must be performed periodically. These include:

- Checking the foreline pump fluid color and level (every week)
- Checking the calibration vial(s) (every 6 months)
- Replacing the foreline pump oil and oil mist filter (every 6 months or as needed)
- Replacing the RIS probe seals (yearly or as needed)

Failure to perform these tasks as scheduled can result in decreased instrument performance. It can also result in damage to your instrument.

Other procedures

Tasks such as replacing an ion vacuum gauge should be performed only when needed by a certified Agilent service personnel. See the *Agilent 7200 Accurate-Mass Q-TOF GC/MS Troubleshooting and Maintenance Manual* and see the online help in the MassHunter WorkStation software for symptoms that indicate this type of maintenance is required.

More information is available

If you need more information about the locations or functions of vacuum system components, see the *Agilent 7200 Accurate-Mass Q-TOF GC/MS Troubleshooting and Maintenance Manual*.

Most of the procedures in this chapter are illustrated with video clips on the Agilent GC/MS Hardware User Information & Instrument Utilities and 7200 Q-TOF GC/MS User Information disks.

Maintaining the Analyzer

Scheduling

None of the analyzer components requires periodic maintenance. Some tasks, however, must be performed when MS behavior indicates they are necessary. These tasks include:

- Cleaning the ion sources
- Replacing filaments

The *Agilent 7200 Accurate-Mass Q-TOF GC/MS Troubleshooting and Maintenance Manual* provides information about symptoms that indicate the need for analyzer maintenance. The troubleshooting material in the online help in the MassHunter Workstation software provides more extensive information.

Precautions

Keep components clean during analyzer maintenance. Never open the analyzer chamber. There are no customer serviceable parts accessible from this door.

CAUTION

If not done correctly, analyzer maintenance can introduce contaminants into the MS.

WARNING

The analyzers operate at high temperatures. Do not touch any part until you are sure it is cool.

Electrostatic discharge

The wires, contacts, and cables connected to the analyzer components can carry electrostatic discharges (ESDs) to the electronics boards to which they are connected. This is especially true of the mass filter (quadrupole) and collision cell contact wires which can conduct ESD to sensitive components on the quad driver board. ESD damage may not cause immediate failure but will gradually degrade performance and stability.

CAUTION

Electrostatic discharges to analyzer components are conducted to the quad driver board where they can damage sensitive components. Wear a grounded antistatic wrist strap and take other antistatic precautions when working on the analyzer.

Analyzer parts that should not be disturbed

The mass filter (quadrupole) and the collision cell require no periodic maintenance. In general, the mass filter should never be disturbed. In the event of extreme contamination, it can be cleaned, but such cleaning should only be done by a trained Agilent Technologies service representative.

CAUTION

Incorrect handling or cleaning of the mass filter can damage it and have a serious, negative effect on instrument performance. Never open the analyzer door.

More information is available

If you need more information about the locations or functions of analyzer components, refer to the *Agilent 7200 Accurate-Mass Q-TOF GC/MS Concepts Guide*.

To Disassemble the EI Ion Source



Materials needed

- Gloves, clean, lint-free
 - Large (8650-0030)
 - Small (8650-0029)
- Hex ball driver, 1.5 mm (8710-1570)
- Hex ball driver, 2.0 mm (8710-1804)
- Wrench, open-end, 10 mm (8710-2353)
- Nut driver, 5.5 mm (8710-1220)
- Tweezers (8710-2460)

Procedure

- 1 Remove the ion source. See [“To Change the Ion Source”](#) on page 78.
- 2 Remove the filaments. See [“To Remove a Filament”](#) on page 109.
- 3 Separate the ion focus and insulator assembly from the source body. (See [Figure 23.](#))
- 4 Remove the two screws from the ion focus insulator and separate it from the ion focus lens.
- 5 Remove the extractor lens and its insulator from the source body.
- 6 Remove the two screws from the RIS bayonet mount on the bottom of the source body, and remove the RIS bayonet mount.
- 7 Remove the repeller assembly from the source body.
- 8 Disassemble the repeller assembly by separating the repeller, the repeller cap, ring heater and sensor assembly. (See [Figure 23.](#))
- 9 Remove the clocking button from the repeller cap by removing the screw that holds it in place. (See [Figure 23.](#))

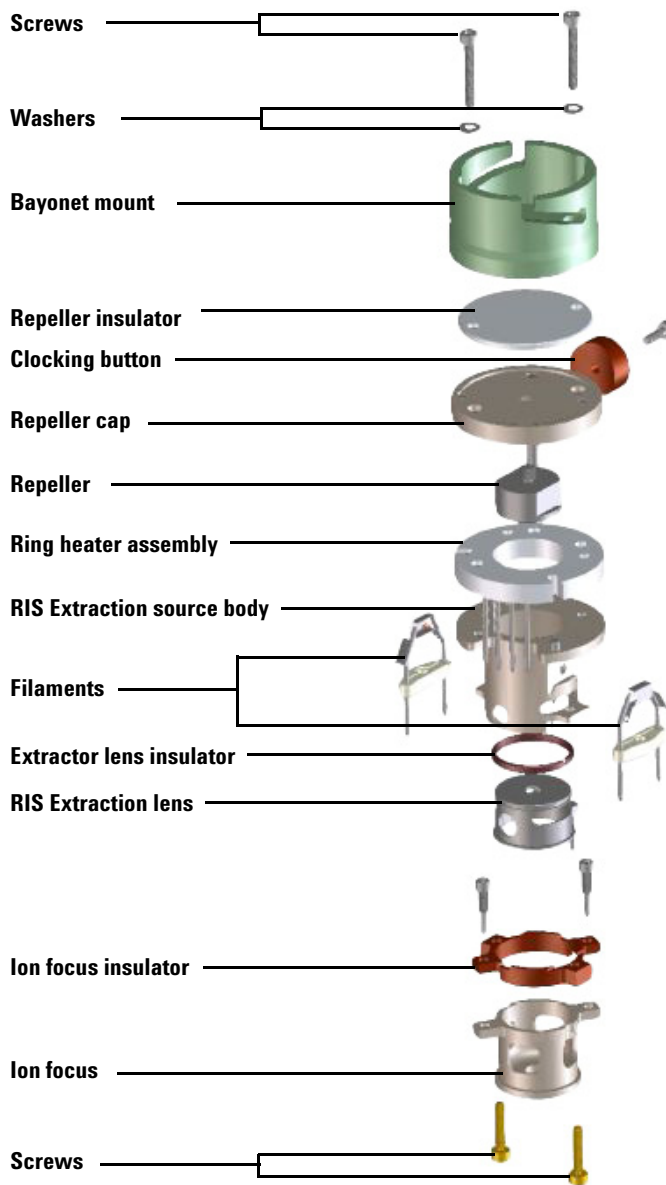

Figure 23 Disassembling the EI ion source

To Assemble the EI Ion Source



Materials needed

- Gloves, clean, lint-free
 - Large (8650-0030)
 - Small (8650-0029)
- Hex ball driver, 1.5 mm (8710-1570)
- Hex ball driver, 2.0 mm (8710-1804)
- Wrench, open-end, 10 mm (8710-2353)

Procedure

CAUTION

Always wear clean gloves when working in the analyzer chamber to avoid contamination.

- 1 Assemble the repeller assembly, by attaching the repeller to the repeller cap and connecting the clocking button with the screw.
- 2 Align the heater sensor with the source body.
- 3 Slide the repeller cap onto the heater sensor, and place the ceramic repeller insulator on top, aligning the screw holes.
- 4 Place the RIS bayonet mount on top of the ceramic repeller insulator, and attach with the washers and screws.
- 5 Attach the extractor lens insulator to the extractor lens, and slide them onto the other end of the source body (Figure 23).
- 6 Place the ion focus insulator on the ion focus lens and attach with the two screws.
- 7 Set the ion focus assembly on top of the extractor lens assembly on the source body.
- 8 Attach the filaments with the two screws.

CAUTION

While installing, do not overtighten the repeller nut or the ceramic repeller insulators will break when the source heats up. The nut should only be finger-tight.

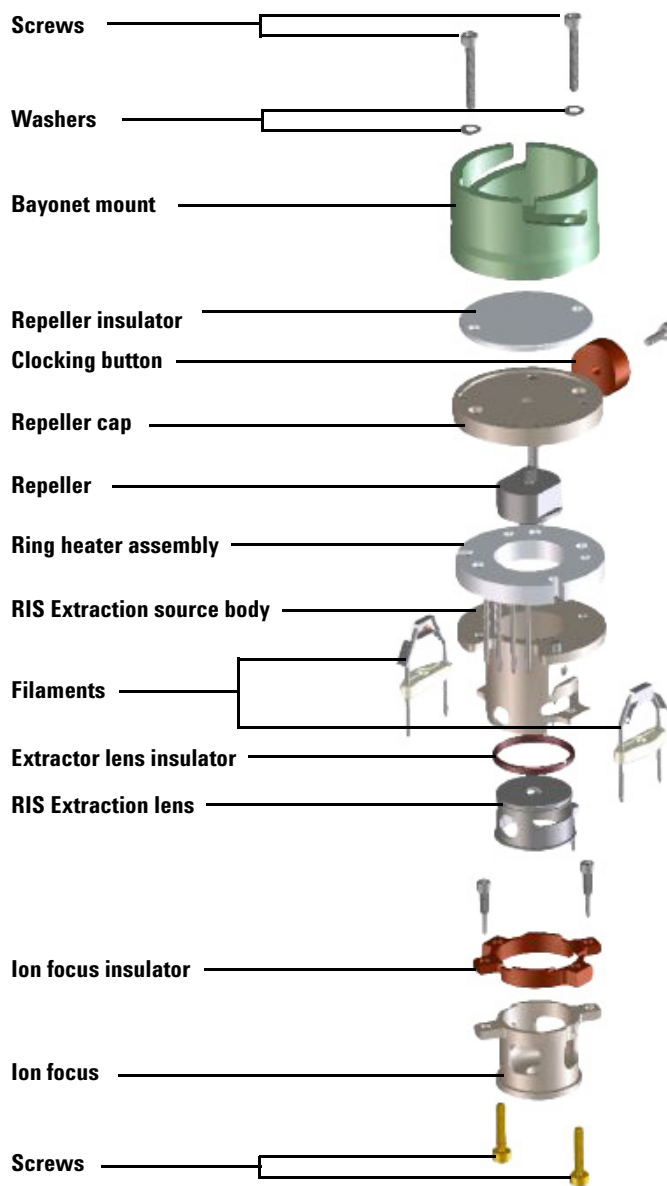

Figure 24 Assembling the EI source

To Disassemble the CI Ion Source



Materials needed

- Gloves, clean, lint-free
 - Large (8650-0030)
 - Small (8650-0029)
- Hex ball driver, 1.5 mm (8710-1570)
- Hex ball driver, 2.0 mm (8710-1804)
- Wrench, open-end, 10 mm (8710-2353)
- Nut driver, 5.5 mm (8710-1220)
- Tweezers (8710-2460)

Procedure

- 1 Remove the CI ion source. See [“To Change the Ion Source”](#) on page 78.
- 2 Remove the filament. See [“To Remove a Filament”](#) on page 109.
- 3 Remove the ion focus lens and insulator. (See [Figure 25](#).)
- 4 Remove the two screws from the ion focus lens insulator and separate it from the ion focus lens.
- 5 Remove the two screws from the RIS bayonet mount and remove the repeller assembly.
- 6 Disassemble the repeller assembly by removing the ceramic insulator and heater assembly from the repeller. (See [Figure 25](#).)
- 7 Take the repeller off the source body.

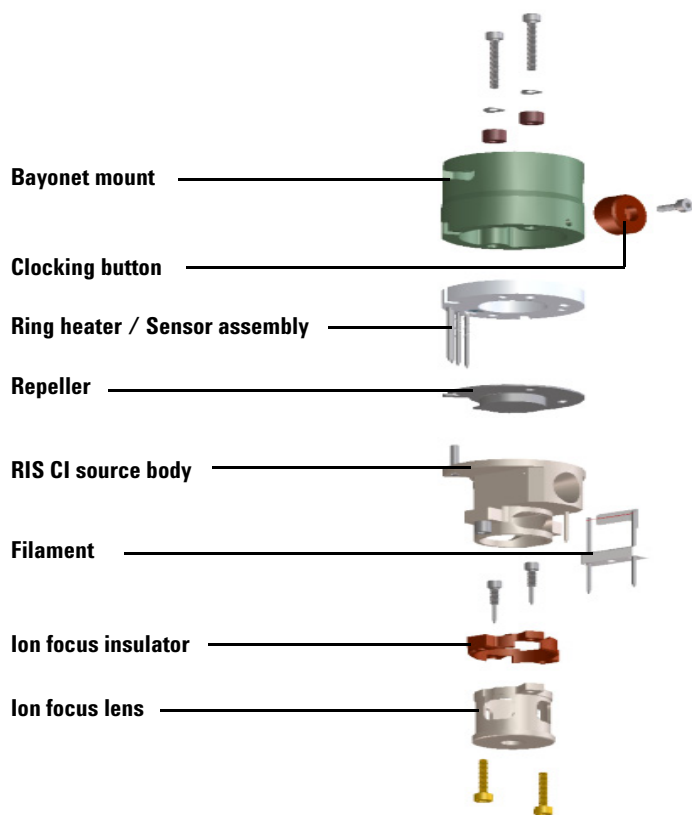

Figure 25 Disassembling the CI ion source

To Assemble the Cl Ion Source



Materials needed

- Gloves, clean, lint-free
 - Large (8650-0030)
 - Small (8650-0029)
- Hex ball driver, 1.5 mm (8710-1570)
- Hex ball driver, 2.0 mm (8710-1804)
- Wrench, open-end, 10 mm (8710-2353)

Procedure

CAUTION

Always wear clean gloves when working in the analyzer chamber to avoid contamination.

- 1 Place the ceramic heater assembly on top of the repeller, aligning the grooves on the repeller with the slot on the heater assembly. (Figure 26).
- 2 Place the repeller on the source body. (Figure 26).
- 3 Place the assembled parts into the RIS bayonet mount, heater side first.
- 4 Align the interface socket in the source body with the alignment groove in the RIS bayonet mount. Attach with the two screws.
- 5 Place the ion focus and ion focus insulator together and attach with the two screws.

CAUTION

While installing, do not overtighten the repeller nut or the ceramic repeller insulator will break when the source heats up. The nut should only be finger-tight.

- 6 Set the filament in place.
- 7 Place the ion focus assembly on the source body, with the insulator against the source body. Ensure all pins are facing in the same direction.
- 8 Attach with the two screws.

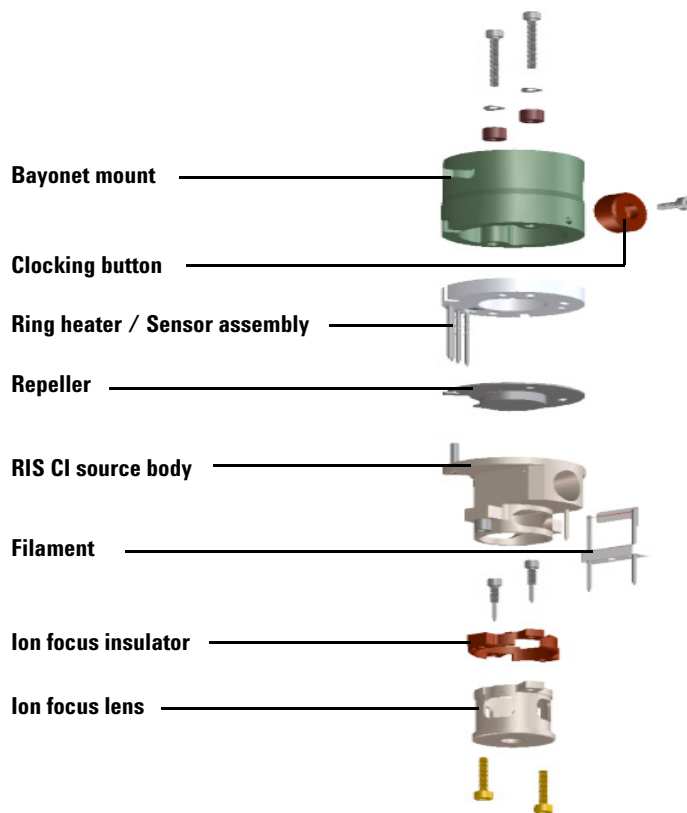

Figure 26 Assembling the CI ion source

To Clean the Ion Source

Frequency of cleaning

Because the CI ion source operates at much higher pressures than the EI ion source, it will probably require more frequent cleaning than the EI ion source. Cleaning of the source is not a scheduled maintenance procedure. The source should be cleaned whenever there are performance anomalies that are associated with a dirty ion source. See the 7200 Q-TOF GC/MS Troubleshooting and Maintenance Manual for symptoms that indicate a dirty ion source.

Visual appearance is not an accurate guide to cleanliness of the CI ion source. The CI ion source can show little or no discoloration yet still need cleaning. Let analytical performance be your guide.

Materials needed

- Abrasive paper (5061-5896)
- Alumina abrasive powder (8660-0791)
- Aluminum foil, clean
- Cloths, clean (05980-60051)
- Cotton swabs (5080-5400)
- Glass beakers, 500 mL
- Gloves, clean, lint-free
 - Large (8650-0030)
 - Small (8650-0029)
- Solvents
 - Acetone, reagent grade
 - Methanol, reagent grade
 - Methylene chloride, reagent grade
- Ultrasonic bath



Preparation

- 1 Disassemble the ion source. See “[To Disassemble the EI Ion Source](#)” on page 97 or “[To Disassemble the CI Ion Source](#)” on page 101.
- 2 Collect the following parts to be cleaned if you are cleaning a high sensitivity extractor EI ion source: ([Figure 27](#))
 - Repeller
 - Source body
 - Extractor lens
 - Ion focus lens

Collect the following parts to be cleaned if you are cleaning a CI source:

- Repeller
- Source body
- Ion focus lens

These are the parts that contact the sample or ion beam. The other parts normally should not require cleaning.

CAUTION

If insulators are dirty, clean them with a cotton swab dampened with reagent-grade methanol. If that does not clean the insulators, replace them. Do not abrasively or ultrasonically clean the insulators.

Cleaning the CI ion source is very similar to cleaning the EI ion source, with the following exceptions:

- The CI ion source may not look dirty but deposits left by chemical ionization are very difficult to remove. Clean the CI ion source thoroughly.
- Use a round wooden toothpick to gently clean out the electron entrance hole in the source body.
- Do not use halogenated solvents. Use hexane for the final rinse.

CAUTION

Do not use halogenated solvents to clean the CI ion source.



Figure 27 Extractor EI Source parts to be cleaned



Figure 28 CI Source parts to be cleaned

CAUTION

The filaments, source heater assembly, and insulators cannot be cleaned ultrasonically. Replace these components if major contamination occurs.

- 3 If the contamination is serious, such as an oil backflow into the analyzer, seriously consider replacing the contaminated parts.

- 4 Abrasively clean the surfaces that contact the sample or ion beam.

Use an abrasive slurry of alumina powder and reagent-grade methanol on a cotton swab. Use enough force to remove all discolorations. Polishing the parts is not necessary; small scratches will not harm performance. Also abrasively clean the discolorations where electrons from the filaments enter the source body.

- 5 Rinse away all abrasive residue with reagent-grade methanol.

Ensure *all* abrasive residue is rinsed away *before* ultrasonic cleaning. If the methanol becomes cloudy or contains visible particles, rinse again.

- 6 Separate the parts that were abrasively cleaned from the parts that were not abrasively cleaned.

CAUTION

Always wear clean gloves to prevent contamination when working in the analyzer chamber.

- 7 Ultrasonically clean the parts (each group separately) for 15 minutes in each of the following solvents:

- Methylene chloride (reagent-grade)
- Acetone (reagent-grade)
- Methanol (reagent-grade)

WARNING

All of these solvents are hazardous. Work in a fume hood and take all appropriate precautions.

- 8 Place the parts in a clean beaker. Loosely cover the beaker with clean aluminum foil (dull side down).
- 9 Dry the cleaned parts in an oven at 100 °C for 5–6 minutes.

To Remove a Filament



Materials needed

- Gloves, clean, lint-free
 - Large (8650-0030)
 - Small (8650-0029)
- Hex ball driver, 1.5 mm (8710-1570)
- Tweezers (8710-2460)

Procedure

CAUTION

Always wear clean gloves to prevent contamination when working in the analyzer chamber.

- 1 Remove the ion source. See [“To Change the Ion Source”](#) on page 78.
- 2 Remove the screw holding the filament to the ion source body. (See [Figure 29](#).)
- 3 Slide the filament off the ion source assembly. (See [Figure 29](#).)

WARNING

The analyzer, GC/MS interface, and other components in the analyzer chamber operate at very high temperatures. Do not touch any part until you are sure it is cool.

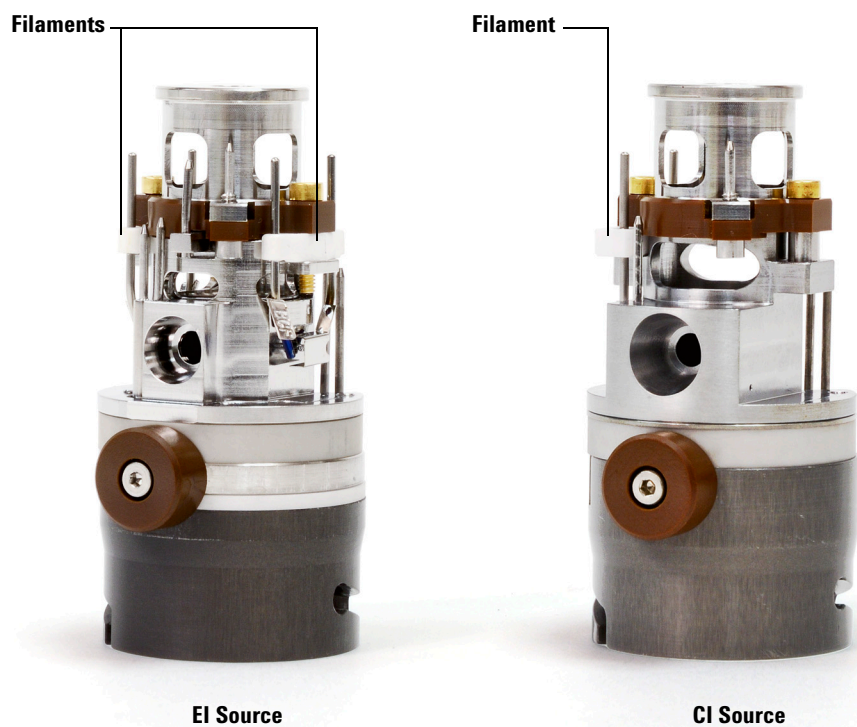

Figure 29 Changing the filament

To Install a Filament

Materials needed

- Filament assembly, EI (G7005-60061)
- Filament assembly, CI (G7005-60072)
- Gloves, clean, lint-free
 - Large (8650-0030)
 - Small (8650-0029)
- Tweezers (8710-2460)

Procedure

- 1 Remove the old filament. (See [“To Remove a Filament”](#) on page 109.)
- 2 Place the new filament into its position on the ion source body. (See [Figure 29](#).)
- 3 Secure the filament to the ion source body with the screw.
- 4 After installing the filament, verify that it is not grounded to source body.
- 5 Reinstall the ion source. (See [“To Change the Ion Source”](#) on page 78.)
- 6 Autotune the MS.

CAUTION

Do not overtighten the thumbscrew; it can cause air leaks or prevent successful pumpdown. Do not use a screwdriver to tighten the thumbscrew.



© Agilent Technologies, Inc.

Printed in USA, August 2014



G3850-90008